

RS 125R/2017 SM 125R/2017

Ed. 02-2017 Rev.01



RS 125R



SM 125R



Catalogo ricambi
Spare parts catalog
Catalogue pieces de rechange
Ersatzteilkatalog
Catalogo piezas de repuestos

INFORMAZIONI GENERALI

Il presente catalogo serve per richiedere con esattezza le parti di ricambio
 Nelle ordinazioni indicare:

- 1) il numero di codice dei particolari seguito dalla descrizione;
 - 2) il colore per i pezzi verniciati o comunque colorati;
 - 3) il numero di matricola del motociclo, stampigliato sul canotto di sterzo.
- Le indicazioni destra e sinistra si riferiscono ai lati del veicolo rispetto al senso di marcia;

GENERAL INFORMATION

The present spare parts list enables one to order exactly the right spare parts.
 When ordering specify:

- 1) the part's code number followed by its description;
 - 2) indicate colour for painted or coloured parts;
 - 3) the motorcycle's serial number, stamped on the steering head.
- References to right and left apply to the vehicle in terms of its direction of movement.

INFORMATIONS GENERALES

Ca catalogue permet de commander correctement les pièces de rechange.
 Les commandes doivent être passées en indiquant:

- 1) le numéro de code des pièces détachées suivi de leur description;
 - 2) le couleur des pièces peintes ou colorés;
 - 3) le matricule de la moto, estampillé sur la tige du guidon.
- Droite et gauche sont les côtés du véhicule par rapport au sens de la marche.

ALLGEMEINE HINWEISE

Dieser Ersatzteilkatalog dient zur genauen Angabe der Teile bei
 Ersatzteilbestellungen.

- Bei Ersatzbestellung ist folgendes anzugeben:
- 1) Die Bestellnummer der Ersatzteile mit der entsprechenden Beschreibung;
 - 2) Farbe für lackierte und farbige Teile angeben;
 - 3) Die Sseriennummer des Motorrads, die am Lenkrohr eingepreßt ist.
- Die Angaben rechts und links beziehen sich auf das Fahrzeug in Fahrrichtung.

INFORMACIONES GENERALES

El presente catálogo sirve para pedir con exactitud las partes de recambio.
 En los pedidos se debe indicar:

- 1) el número de código de la parte y a continuación la descripción;
 - 2) el color para las piezas barnizadas o coloreadas;
 - 3) el número de matrícula de la motocicleta, estampado en el tubo de dirección.
- Las indicaciones derecha e izquierda se refieren a los lados del vehículo respecto del sentido de marcha.

Dati indicativi soggetti a modifiche senza impegno di preavviso.
 All data are subject to modification without prior notice.
 Données indicatif sujet au modifications sans obligation de préavis.
 Änderungen Vorbehalten.
 Datos indicativos sujetos a modificaciones sin compromiso de preaviso.

NOTE - LIST - NOTES - NOTE - NOTAS:

- AUS : Australia, Australia, Australie, Australien, Australia
 CDN : Canada, Canada, Canada, Kanada, Canadá
 IT : Italia, Italy, Italie, Italien, Italia
 JAP : Giappone, Japan, Japon, Japan, Japón
 USA : Stati Uniti d'America, United States of America, Etats Units d'Amerique,
 Vereinigte Staaten von Amerika, Estados Unidos
- A : Codice colore A (Rosso / Bianco), Color code A (Red / White),
 Code couleur A (Rouge / Blanc), Code Farbe A (Rot / Weiß),
 Codigo de color A (Rojo / Blanco)
- B : Codice colore B (Nero), Color code B (Black), Code couleur B (Noir),
 Code Farbe B (Schwarz), Codigo de color B (Negro)

N° DI MATRICOLA INIZIALE - INITIAL SERIAL NUMBER - MATRICULE INITIAL - BEGINNTESEERIENNUMMER - MATRICULA INICIAL	
MODELLO - MODEL MODELE - MODELL MODELO	MATRICOLA - SERIAL NUMBER MATRICULE - SERIENNUMMER MATRICULA
RS 125R	ZN0B201AAHV000000
SM 125R	ZN0B201ABHV000000



INDICE – INDEX – INDEX – INHALTSVERZEICHNIS - INDICE

RS 125R/2017
SM 125R/2017

Tavola Drawing Table Bild Tabla	Denominazione	Description	Designation	Bezeichnung	Denominacion	Pagina Page Seite Paja
1	ATTREZZI DI ASSISTENZA, MANUALI E CATALOGHI	SERVICE TOOLS, MANUALS AND CATALOGS	OUTILS D'ASSISTANCE, MANUELS ET CATALOGUES	HILFAUSRUSTUNG, HANDBUCH UND KATALOG	HERRAMIENTAS DE ASISTENCIA, MANUALES Y CATALOGOS	13
2	CILINDRO, PISTONE	CYLINDER, PISTON	CYLINDRE, PISTON	ZYLINDER, KOLBEN	CILINDRO, PISTON	15
3	TESTA CILINDRO	CYLINDER HEAD	CULASSE	ZYLINDERKOPF	CULATA	17
4	COPERCHIO VALVOLE	VALVE COVER	COUVERCLE CULASSE	ZYLINDERKOPFDECKEL	TAPA CULATA	19
5	MANOVELLISMO	CRANKSHAFT	VILEBREQUIN	KURBELWELLE	CIGÜEÑAL	21
6	DISTRIBUZIONE	VALVE TIMING	DISTRIBUTION	VENTILSTEUERUNG	DISTRIBUCION	23
7	LUBRIFICAZIONE	OIL PUMP	PUMPE HUILE	MOTORSCHMIERUNG	LUBRICACION	25
8	COPERCHIO CARTER SINISTRO	LEFT CRANKCASE COVER	COUVERCLES CARTER GAUCHE	GEHAUSEDECKEL LINKS	TAPAS BANCADA IZQUIERDA	27
9	SEMICARTER SINISTRO	LEFT HALF CRANKCASE	CARTER GAUCHE	GEHAUSEDECKEL LINKS	BANCADA IZQUIERDA	29
10	SEMICARTER DESTRO	RIGHT HALF CRANKCASE	CARTER DROIT	GEHAUSEDECKEL RECHTS	BANCADA DERECHO	31
11	FRIZIONE	CLUTCH	EMBAYAGE	KUPPLUNG	EMBRAGUE	33
12	COMANDO CAMBIO	GEARSHIFT MECHANISM	COMMANDE DE VITESSE	GANGSCHALTUNG	MANDO CAMBIO	35
13	PARTE ELETTRICA	IGNITION SISTEM	PARTIES ELECTRIQUE	ELEKTRISCHE TEILE	PARTE ELECTRICA	37
14	AVVIAMENTO	STARTING	DEMARRAGE	ANLASSER	ARRANQUE	39
15	CORPO FARFALLATO	THROTTLE BODY	CORP PAPILLON	DROSSELKLAPPENKÖRPER	CUERPO OSCILANTE	41
16	IMPIANTO RAFFREDAMENTO OLIO	OIL COOLING SYSTEM	INSTALLATION RAFROIDISSEMENT HUILE	ÖL SCHMIERUNGSSYSTEM	EQUIPO DE ENFRIAMIENTO ACEITE	43
17	FILTRO ARIA	AIR FILTER	FILTRE AIRE	LUFTFILTER	FILTRO DE AIRE	47
18	TELAIO, PEDANE	FRAME, FOOT RESTS	CADRE, REPOSE PIEDS	RAHMEN, FUSSBRETT	BASTIDOR, REPOSAPIES	49
19	SOSPENSIONE ANTERIORE	FRONT FORK ASSEMBLY	SUSPENSION AVANT	VORDETELESKOPGABEL	SUSPENSION DELANTERA	53
19A	FORCELLA DESTRA	RIGHT FORK	FOURCHE DROIT	GABEL RECHTS	HORQUILLA DERECHA	55
19B	FORCELLA SINISTRA	LEFT FORK	FOURCHE GAUCHE	GABEL LINKS	HORQUILLA IZQUIERDA	57
20	AMMORTIZZATORE POSTERIORE	REAR SUSPENSION	SUSPENSION ARRIERE	HINTERHAUFHANGUNG	SUSPENSION TRASERA	59
21	LEVRAGGI SOSPENSIONI POSTERIORE	REAR SUSPENSION LINKAGE	LEVIER SUSPENSION ARRIERE	HEBELWERK HINTERHAUFHANGUNG	PALANCA SUSPENSION TRASERA	61
22	FORCELLONE POSTERIORE	REAR SWING ARM	FOURCHE ARRIERE	HINTERGABEL	HORQUILLA TRASERA	63
23	MANUBRIO E COMANDI	HANDLEBAR AND CONTROLS	GUIDON ET COMMANDES	LENKER UND STEUERORGANE	MANILLAR Y MANDOS	65
24	PANNELLI, PARAFANGHI, SELLA	PANEL, FENDERS, SEAT,	PANNEAU, GARDE-BOUES, SIEGE,	STREIFEN, KOTFLUGEL, SATTEL	PANELO, GUARDABARROS, SILLIN	67
25	SERBATOIO CARBURANTE, CONVOGLIATORI	GAS TANK, PANEL	RESERVOIR CARBURANT, FLANC	KRAFTSTOFFBEHALTER, FLANKE	DEPOSITO GASOLINA, LATERAL	71
26	SCARICO	EXHAUST SYSTEM	TUYAU D'ECHAPPEMENT	AUSPUFFROHR	TUBO DE ESCAPE	75
27	FRENO IDRAULICO ANTERIORE	FRONT HYDRAULIC BRAKE	FREIN HYDRAULIQUE AVANT	VORDERBREMSE	FRENO HIDRAULICO DELANTERO	77
28	FRENO IDRAULICO POSTERIORE	REAR HYDRAULIC BRAKE	FREIN HYDRAULIQUE ARRIERE	HINTERBREMSE	FRENO HIDRAULICO TRASERO	79
29	RUOTA ANTERIORE (RS 125R)	FRONT WHEEL (RS 125R)	ROUE AVANT (RS 125R)	VORTERRAD (RS 125R)	RUEDA DELANTERA (RS 125R)	81



INDICE - INDEX - INDEX - INHALTSVERZEICHNIS - INDICE

RS 125R/2017
SM 125R/2017

Tavola - Drawing - Table - Bild - Tabla

1

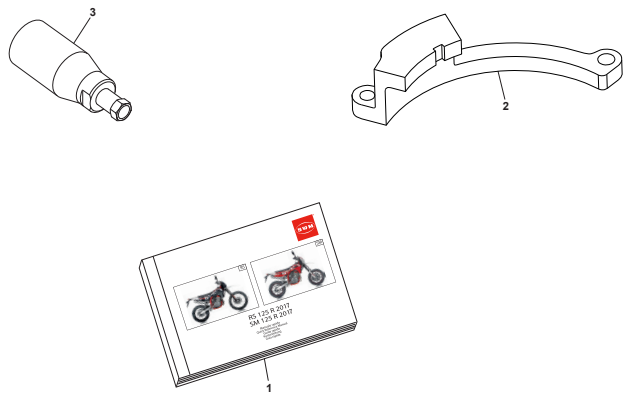

Pagina - Page - Page - Seite - Paja

12

Tavola - Drawing - Table - Bild - Tabla

2

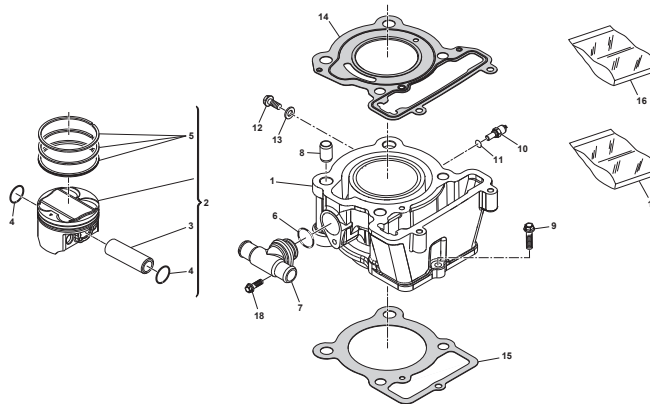

Pagina - Page - Page - Seite - Paja

14

Tavola - Drawing - Table - Bild - Tabla

3

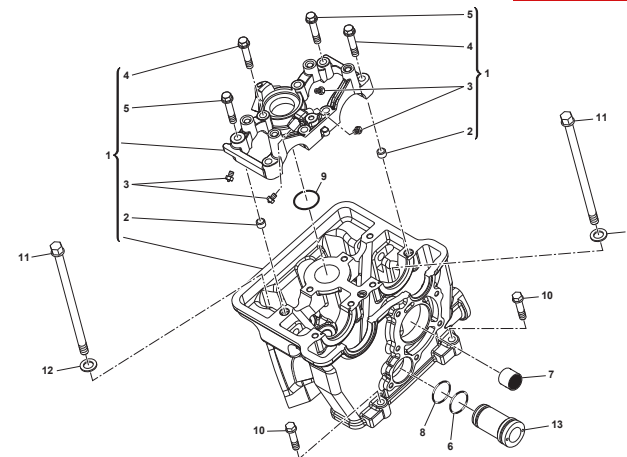

Pagina - Page - Page - Seite - Paja

16

Tavola - Drawing - Table - Bild - Tabla

4

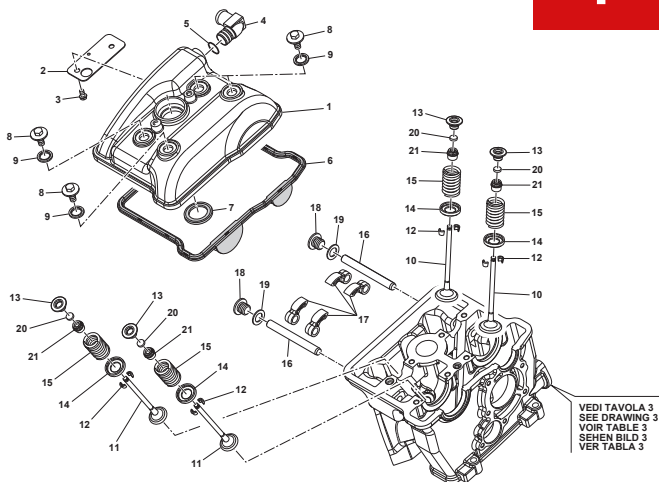

Pagina - Page - Page - Seite - Paja

18

Tavola - Drawing - Table - Bild - Tabla

5

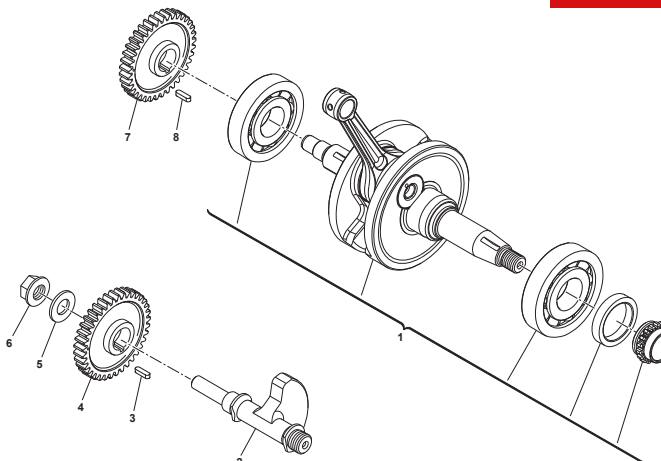

Pagina - Page - Page - Seite - Paja

20

Tavola - Drawing - Table - Bild - Tabla

6

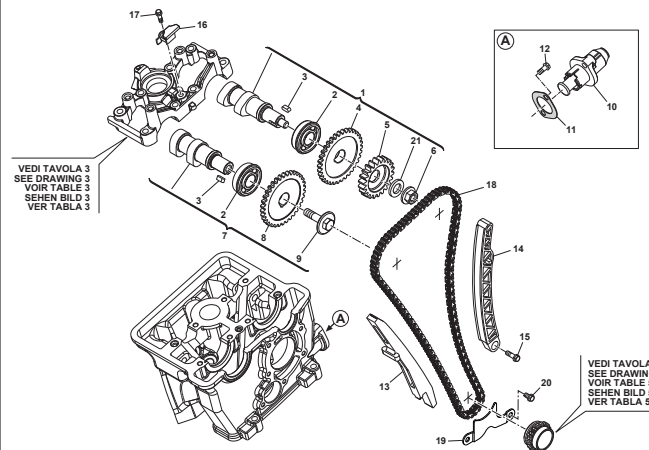

Pagina - Page - Page - Seite - Paja

22

Tavola - Drawing - Table - Bild - Tabla

7

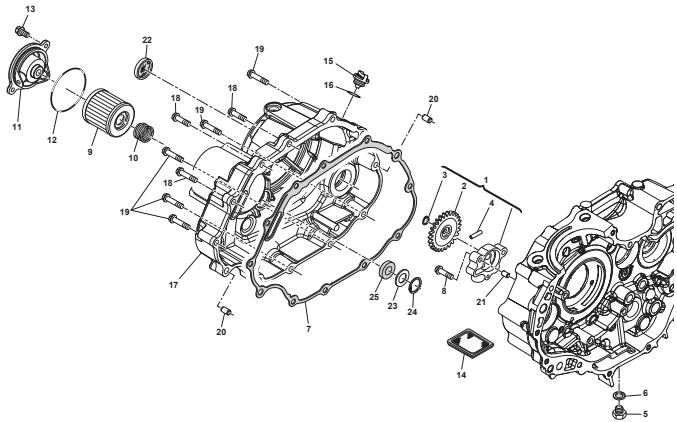

Pagina - Page - Page - Seite - Paja

24

Tavola - Drawing - Table - Bild - Tabla

8

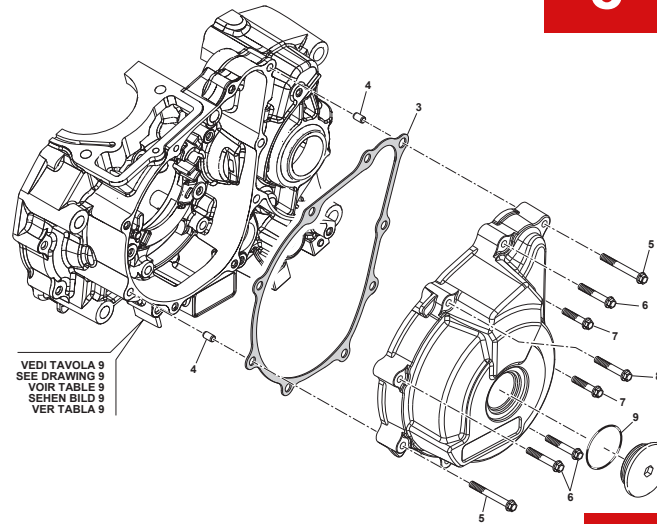

VEDI TAVOLA 9
SEE DRAWING 9
VOIR TABLE 9
SEHEN BILD 9
VER TABLA 9

Pagina - Page - Page - Seite - Paja

26

Tavola - Drawing - Table - Bild - Tabla

9

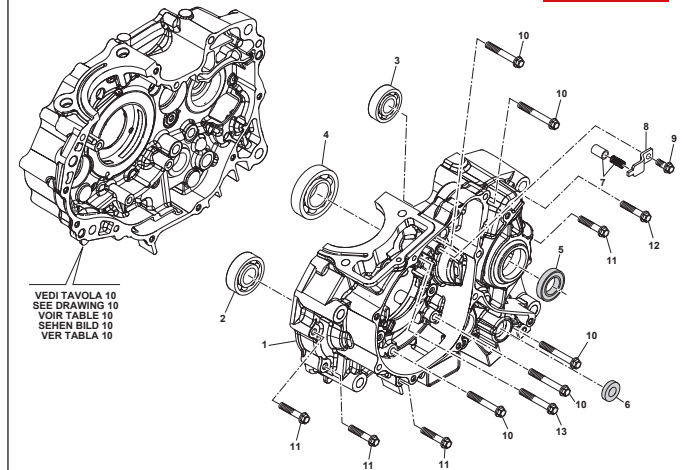

VEDI TAVOLA 10
SEE DRAWING 10
VOIR TABLE 10
SEHEN BILD 10
VER TABLA 10

Pagina - Page - Page - Seite - Paja

28

Tavola - Drawing - Table - Bild - Tabla

10

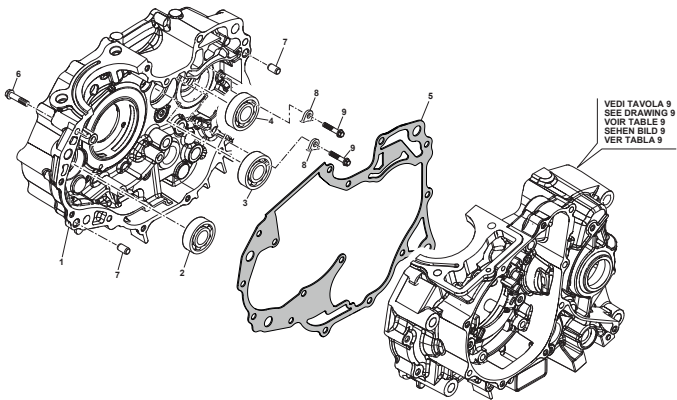

VEDI TAVOLA 9
SEE DRAWING 9
VOIR TABLE 9
SEHEN BILD 9
VER TABLA 9

Pagina - Page - Page - Seite - Paja

30

Tavola - Drawing - Table - Bild - Tabla

11

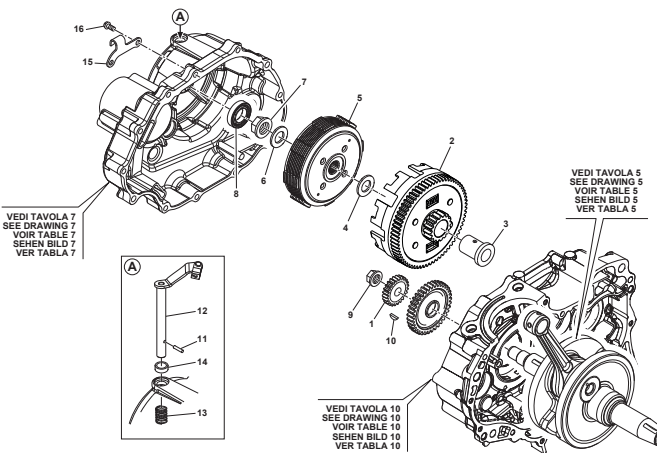

VEDI TAVOLA 7
SEE DRAWING 7
VOIR TABLE 7
SEHEN BILD 7
VER TABLA 7

VEDI TAVOLA 5
SEE DRAWING 5
VOIR TABLE 5
SEHEN BILD 5
VER TABLA 5

VEDI TAVOLA 10
SEE DRAWING 10
VOIR TABLE 10
SEHEN BILD 10
VER TABLA 10

Pagina - Page - Page - Seite - Paja

32

Tavola - Drawing - Table - Bild - Tabla

12

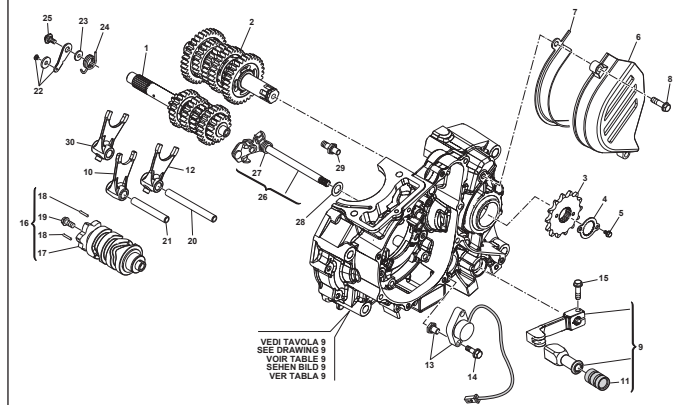

VEDI TAVOLA 9
SEE DRAWING 9
VOIR TABLE 9
SEHEN BILD 9
VER TABLA 9

Pagina - Page - Page - Seite - Paja

34

Tavola - Drawing - Table - Bild - Tabla

13

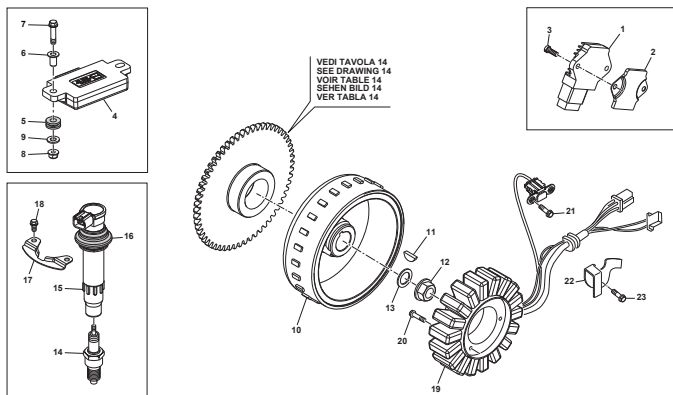

Pagina - Page - Page - Seite - Paja

36

Tavola - Drawing - Table - Bild - Tabla

14

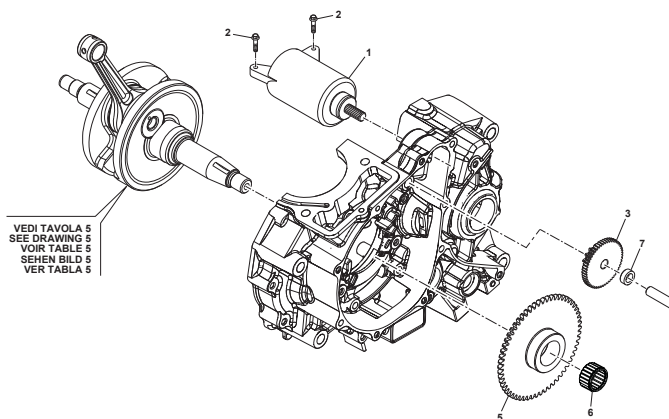

Pagina - Page - Page - Seite - Paja

38

Tavola - Drawing - Table - Bild - Tabla

15

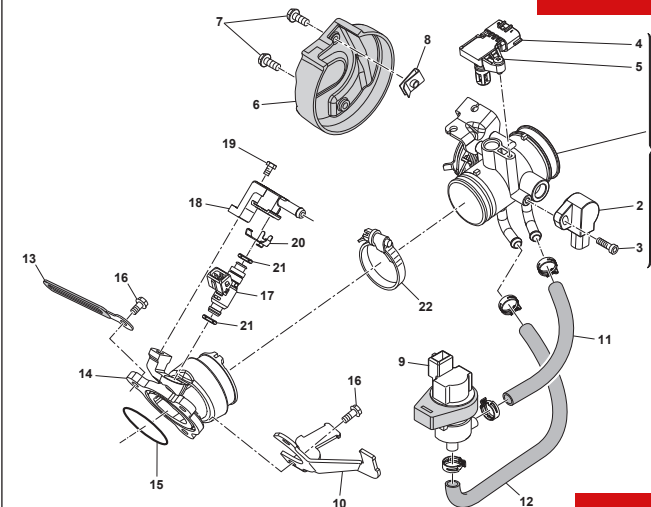

Pagina - Page - Page - Seite - Paja

40

Tavola - Drawing - Table - Bild - Tabla

16

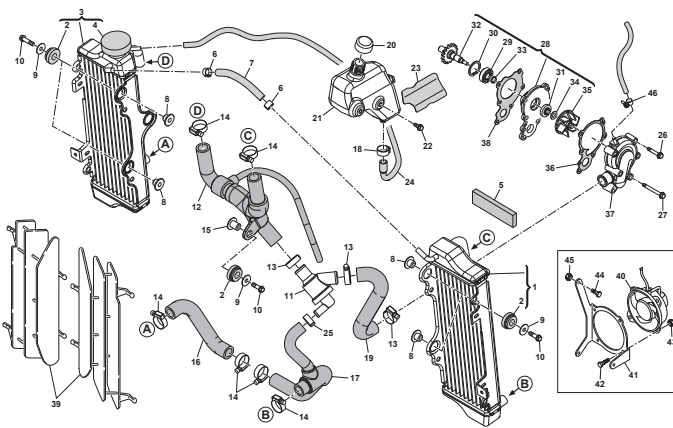

Pagina - Page - Page - Seite - Paja

42

Tavola - Drawing - Table - Bild - Tabla

17

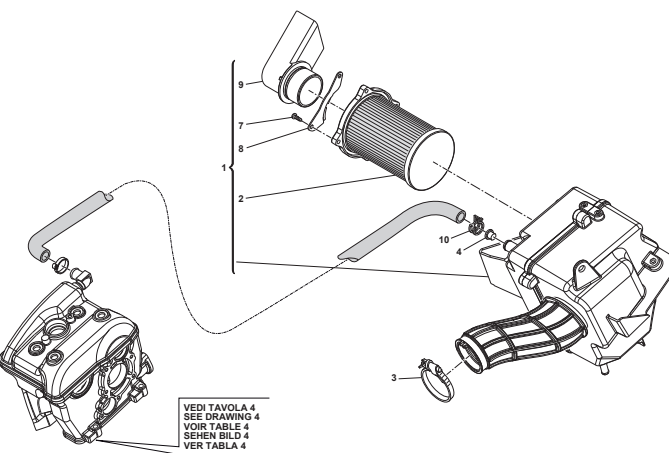

Pagina - Page - Page - Seite - Paja

46

Tavola - Drawing - Table - Bild - Tabla

18

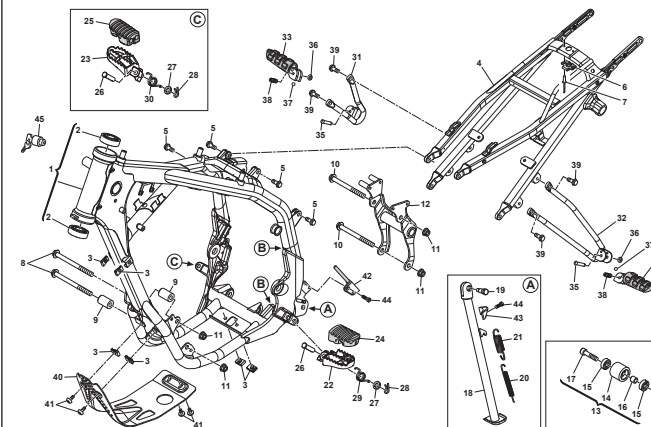

Pagina - Page - Page - Seite - Paja

48

Tavola - Drawing - Table - Bild - Tabla

19

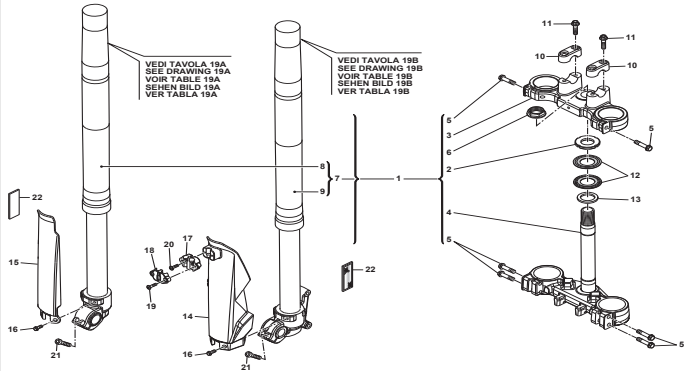

Pagina - Page - Page - Seite - Paja

52

Tavola - Drawing - Table - Bild - Tabla

19A

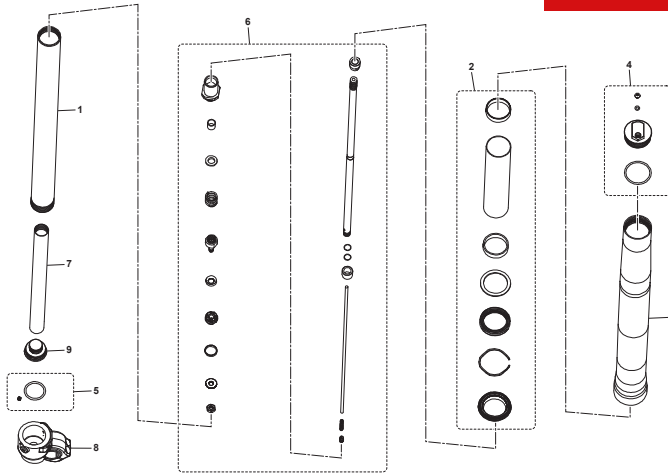

Pagina - Page - Page - Seite - Paja

54

Tavola - Drawing - Table - Bild - Tabla

19B

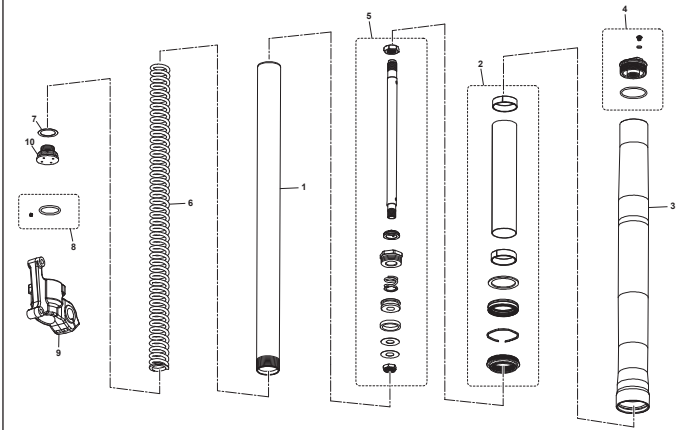

Pagina - Page - Page - Seite - Paja

56

Tavola - Drawing - Table - Bild - Tabla

20

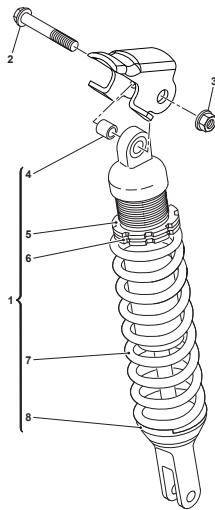

Pagina - Page - Page - Seite - Paja

58

Tavola - Drawing - Table - Bild - Tabla

21

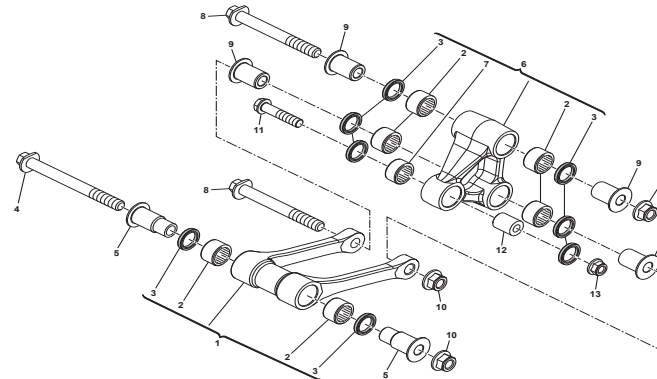

Pagina - Page - Page - Seite - Paja

60

Tavola - Drawing - Table - Bild - Tabla

22

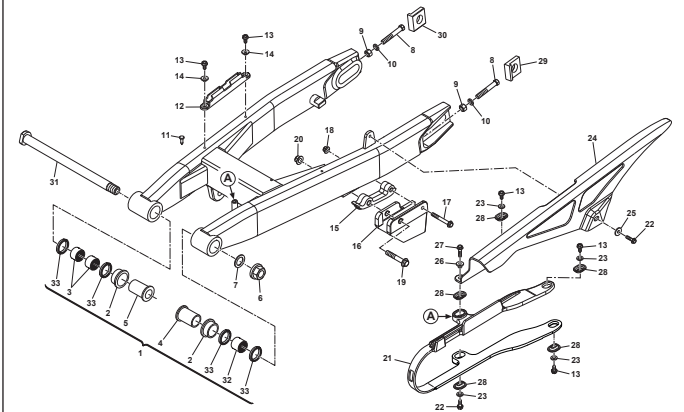

Pagina - Page - Page - Seite - Paja

62

Tavola - Drawing - Table - Bild - Tabla

23

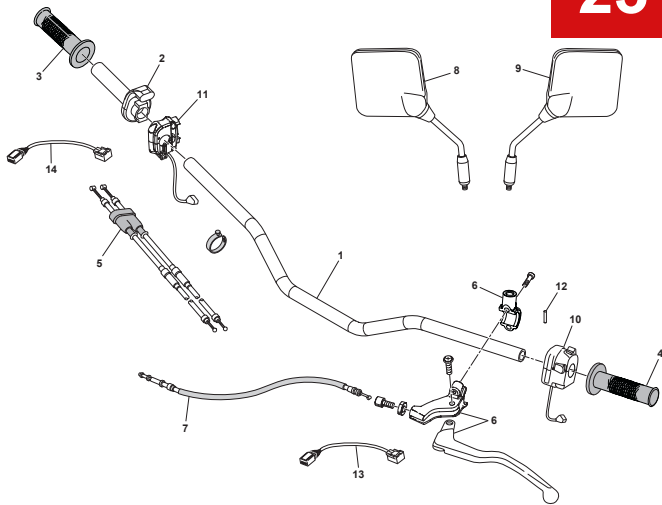

Pagina - Page - Page - Seite - Paja

64

Tavola - Drawing - Table - Bild - Tabla

24

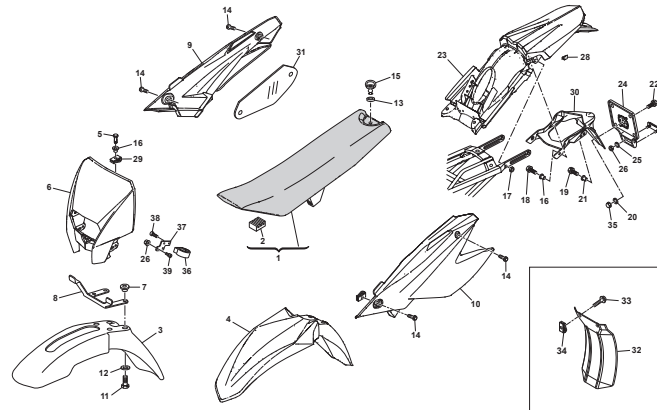

Pagina - Page - Page - Seite - Paja

66

Tavola - Drawing - Table - Bild - Tabla

25

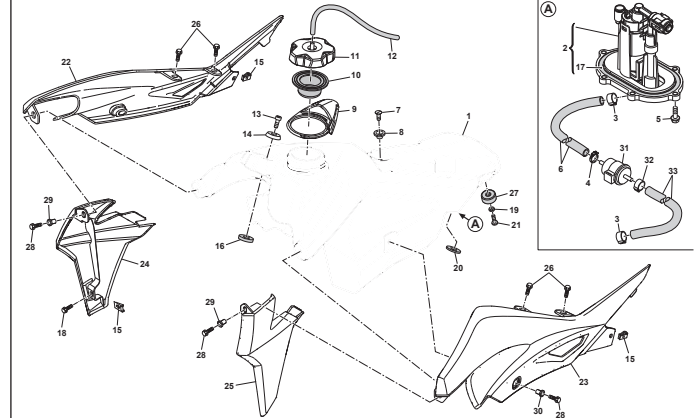

Pagina - Page - Page - Seite - Paja

70

Tavola - Drawing - Table - Bild - Tabla

26

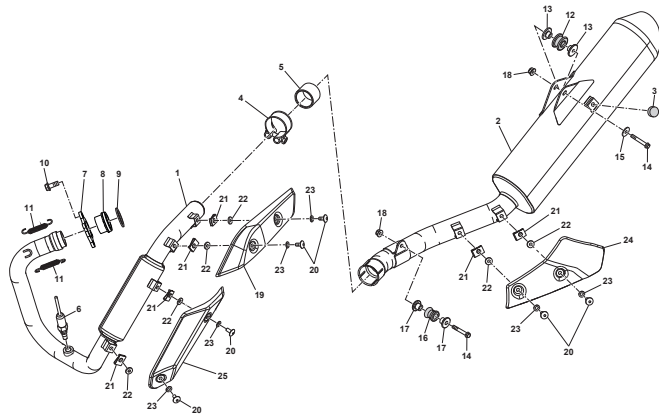

Pagina - Page - Page - Seite - Paja

74

Tavola - Drawing - Table - Bild - Tabla

27

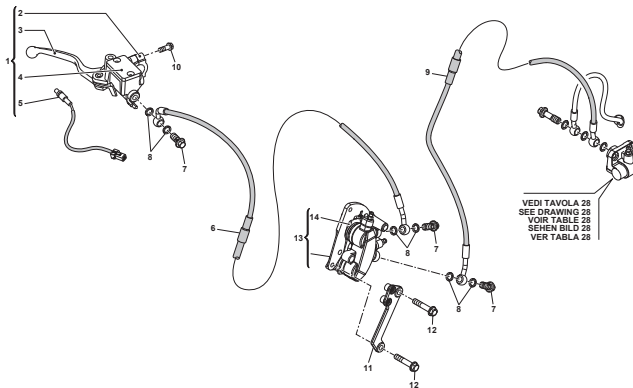

Pagina - Page - Page - Seite - Paja

76

Tavola - Drawing - Table - Bild - Tabla

28

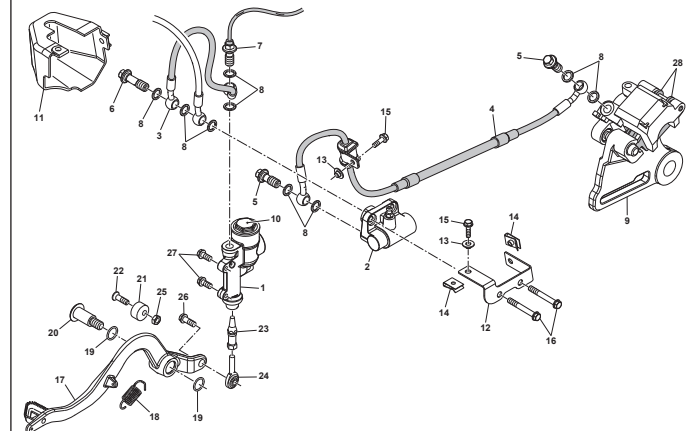

Pagina - Page - Page - Seite - Paja

78

Tavola - Drawing - Table - Bild - Tabla

29

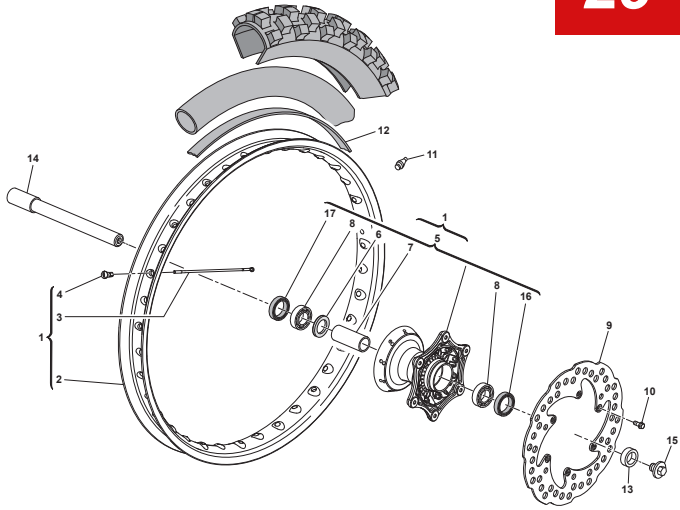

Pagina - Page - Page - Seite - Paja

80

Tavola - Drawing - Table - Bild - Tabla

29A

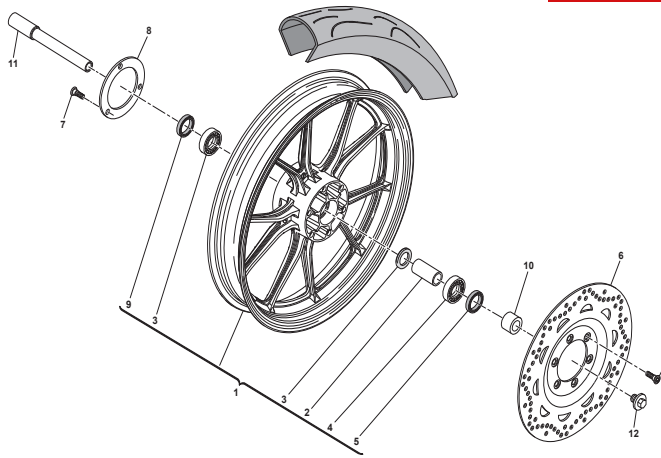

Pagina - Page - Page - Seite - Paja

82

Tavola - Drawing - Table - Bild - Tabla

30

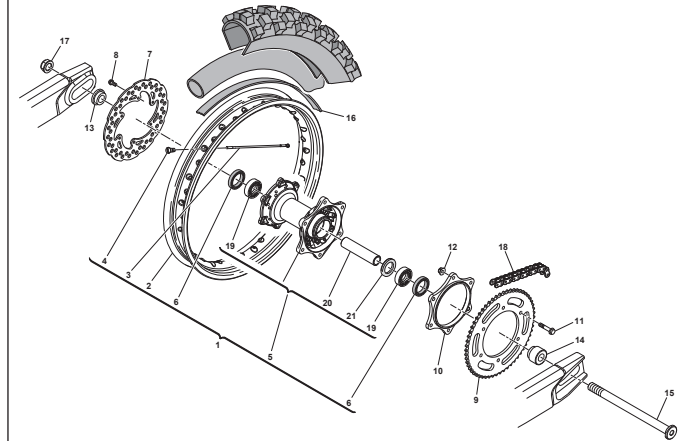

Pagina - Page - Page - Seite - Paja

84

Tavola - Drawing - Table - Bild - Tabla

30A

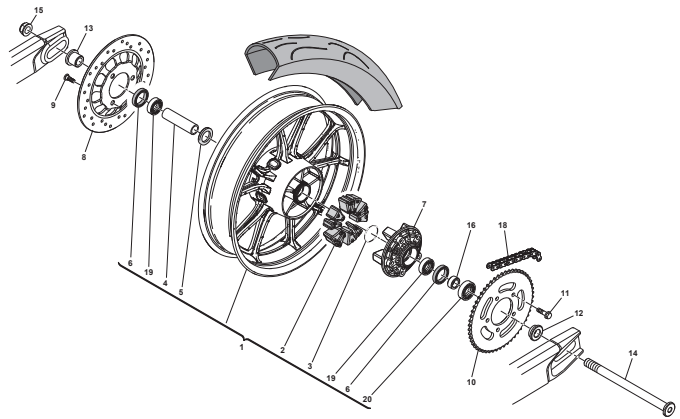

Pagina - Page - Page - Seite - Paja

86

Tavola - Drawing - Table - Bild - Tabla

31

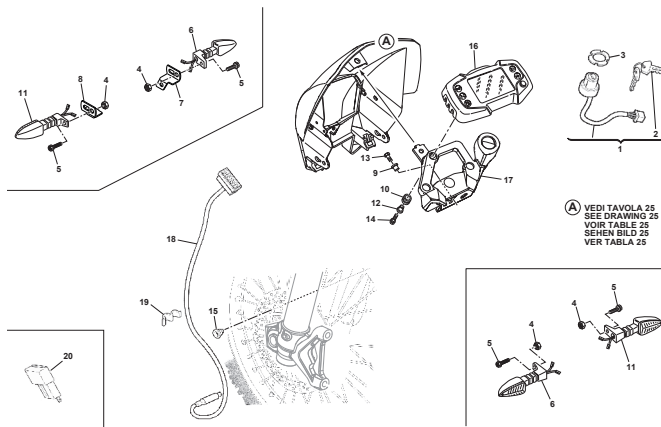

Pagina - Page - Page - Seite - Paja

88

Tavola - Drawing - Table - Bild - Tabla

32

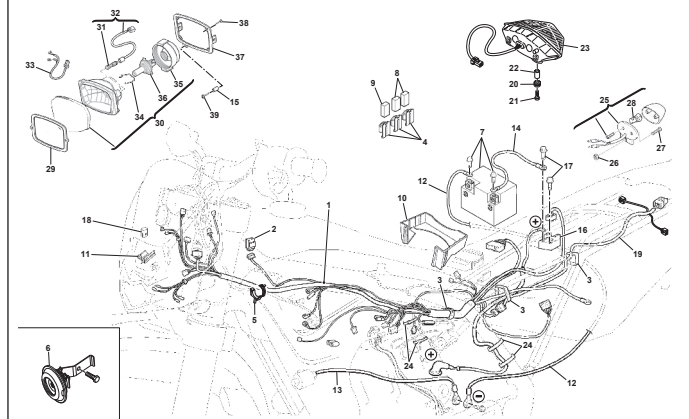

Pagina - Page - Page - Seite - Paja

90



INDICE - INDEX - INDEX - INHALTSVERZEICHNIS - INDICE

**RS 125R/2017
SM 125R/2017**

Tavola - Drawing - Table - Bild - Tabla

33

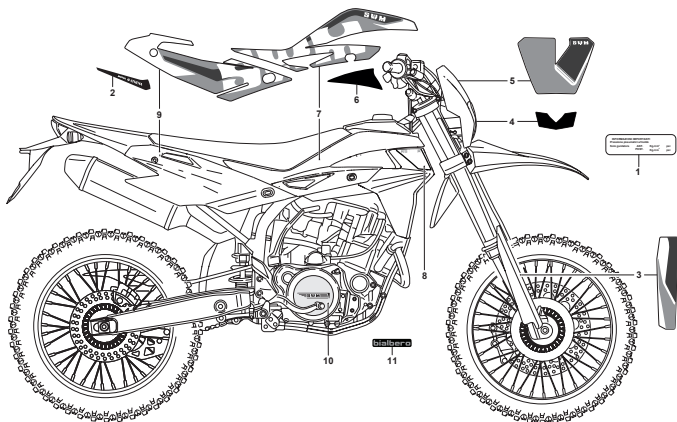

Pagina - Page - Page - Seite - Paja

94

Tavola - Drawing - Table - Bild - Tabla

34

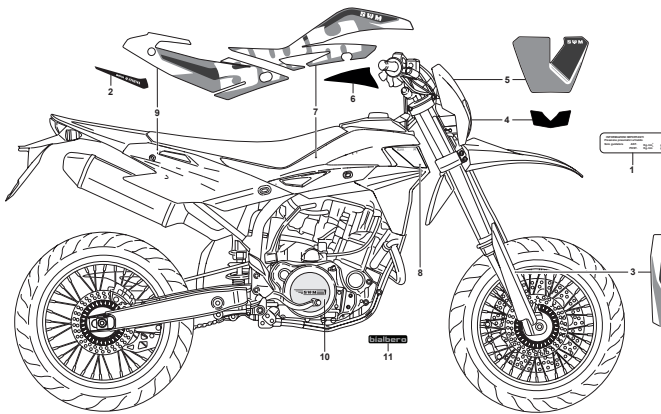

Pagina - Page - Page - Seite - Paja

96

Tavola - Drawing - Table - Bild - Tabla



Pagina - Page - Page - Seite - Paja



Tavola - Drawing - Table - Bild - Tabla



Pagina - Page - Page - Seite - Paja



Tavola - Drawing - Table - Bild - Tabla



Pagina - Page - Page - Seite - Paja



Tavola - Drawing - Table - Bild - Tabla



Pagina - Page - Page - Seite - Paja



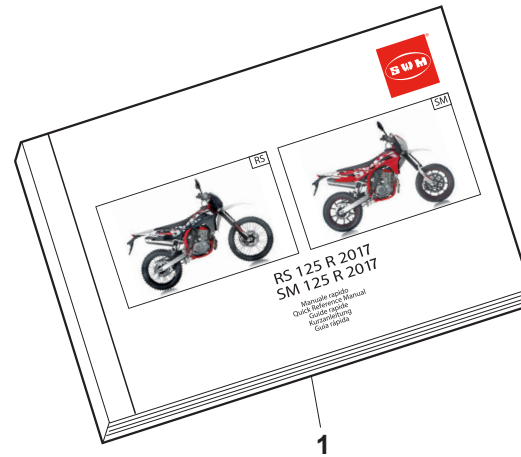
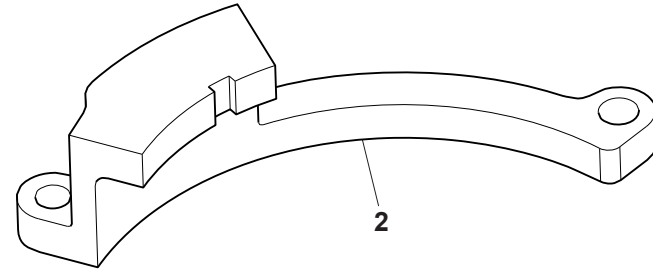
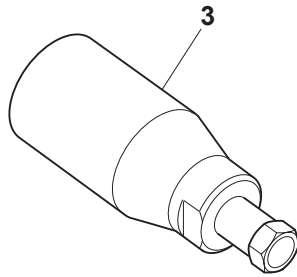

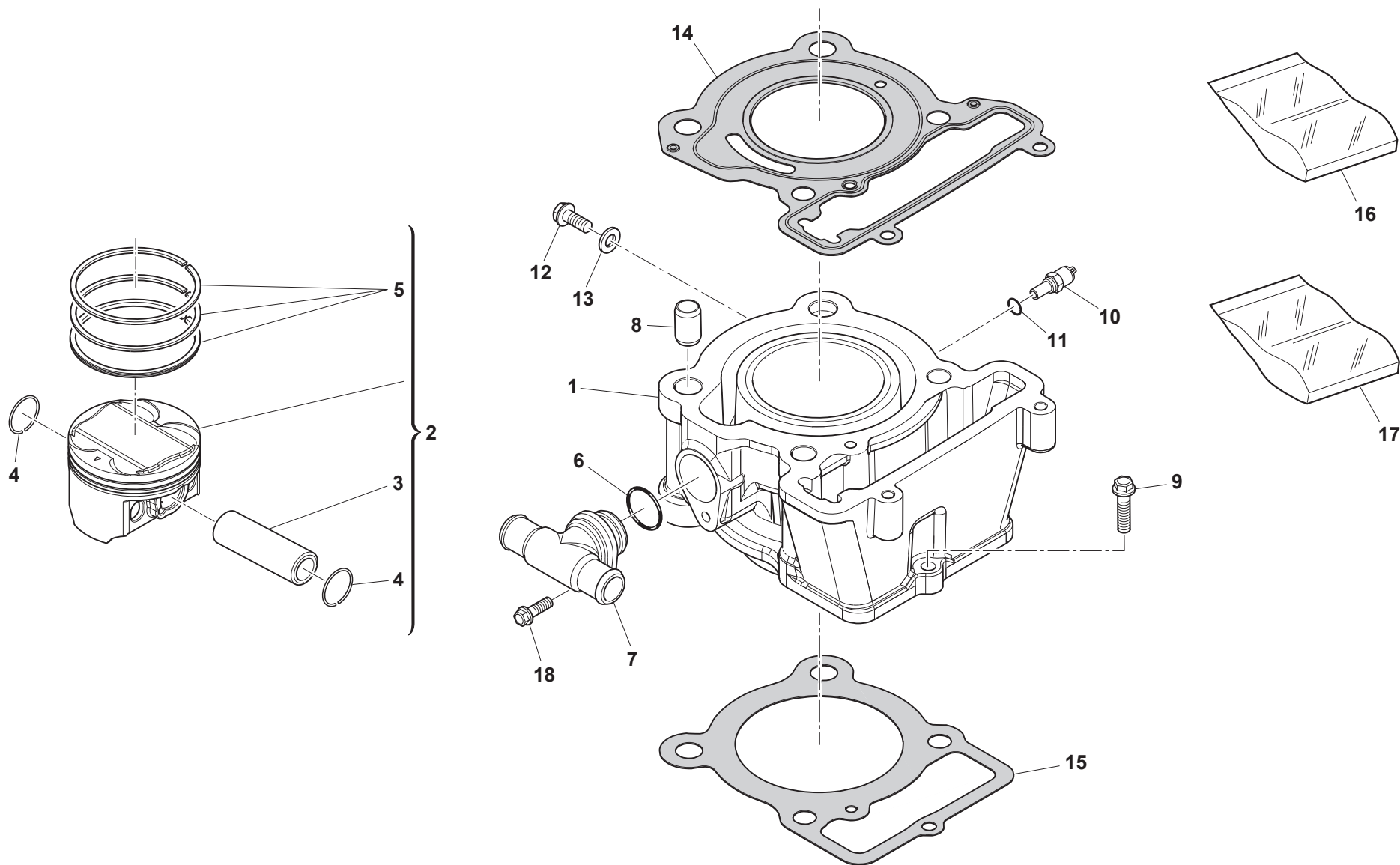



RS 125R/2017
SM 125R/2017

CILINDRO, PISTONE - CYLINDER, PISTON
CYLINDRE, PISTON- ZYLINDER, KOLBEN
CILINDRO, PISTON

TAVOLA
DRAWING
TABLE
BILD
TABLA

2

Note Notes Notes Marke Notas	Pos. No. Index Pos.	N. Cod. Code No. Nr. Code Code Nr N. Cod.	Q.tà Q.ty Q.te M.ge C.ad	DENOMINAZIONE	NAME	DESIGNATION	BESHREIBUNG	DENOMINACION
	1	27010707	1	CILINDRO MOTORE	CYLINDER	CYLINDRE	ZYLINDER	CILINDRO
	2	76220001	1	ASSIEME PISTONE COMPLETO	COMPLETE PISTON ASSY	PISTON COMPLET	ZUSAMMENBAU KOLBEN KOMPLETT	CONJUNTO PISTÓN COMPLETO
	3	21040047	1	SPINOTTO	PISTON PIN	GOUJON	KOLBENBOLZEN	EJE DE PISTON
	4	72080133	2	ANELLO RITEGNO SPINOTTO	PISTON PIN RETAINING RING	BAGUE DE RETENUE GOUJON	RÜCKHALTERING KOLBENBOLZEN	ANILLO DE RETENCION EJE DE PISTON
	5	21030599	1	KIT SEGMENTI PISTONE	PISTON RING KIT	KIT SEGMENTS PISTON	SATZ KOLBENRINGE	KIT SEGMENTOS PISTÓN
	6	72150236	1	ANELLO OR	O-RING	JOINT TORIQUE	O-RING	JUNTA TORICA
	7	17050010	1	RACCORDO	UNION	RACCORD	ANSCHLUSS	RACOR
	8	72060169	4	BUSSOLA Ø12x10	DOWEL PIN Ø12x10	DOUILLE Ø12x10	BUCHSE Ø12x10	CASQUILLO Ø12x10
	9	72012194	1	VITE TCEI M6x23	SCREW TCEI M6x23	VIS TCEI M6x23	SCHRAUBE TCEI M6x23	TORNILLO TCEI M6x23
	10	8000H3649	1	SENSORE TEMPERATURA ACQUA	WATER TEMPERATURE SENSOR	CAPTEUR DE TEMPÉRATURE EAU	WASSERTEMPERATURESENSOR	SENSOR TEMPERATURAAGUA
	11	8A0023108	1	ANELLO OR	O-RING	JOINT TORIQUE	O-RING	JUNTA TORICA
	12	72010155	1	VITE TEF M6x12	FLANGED EXAGON HEAD SCREW M6x12	BOULON DE BRIDE M6x12	FLANSCHENSCHRAUBE M6x12	TORNILLO DE REBORDE M6x12
	13	72040157	1	ROSETTA IN RAME	COPPER WASHER	RONDELLE	UNTERLEGSscheibe	ARANDELA
	14	72130612	1	GUARNIZIONE TESTA	HEAD GASKET	JOINT CULASSE	ZYLINDERKOPFDICHTUNG	JUNTA CULATA
	15	72130636	1	GUARNIZIONE CILINDRO	CYLINDER GASKET	JOINT CYLINDRE	ZYLINDERDICHTUNG	JUNTA CILINDRO
	16	M000A01635	1	KIT GUARNIZIONI MOTORE	ENGINE GASKET KIT	KIT JOINTS MOTEUR	SATZ MOTORDICHTUNGEN	KIT JUNTAS MOTOR
	17	M000A01636	1	KIT ANELLI DI TENUTA MOTORE	ENGINE SEALING RING KIT	KIT BAGUES D'ÉTANCHÉITÉ MOTEUR	SATZ DICHTUNGSRINGE MOTOR	KIT ANILLOS DE ESTANQUEIDAD MOTOR
	18	72010157	1	VITE TEF M6x16	FLANGED EXAGON HEAD SCREW M6x16	BOULON DE BRIDE M6x16	FLANSCHENSCHRAUBE M6x16	TORNILLO DE REBORDE M6x16

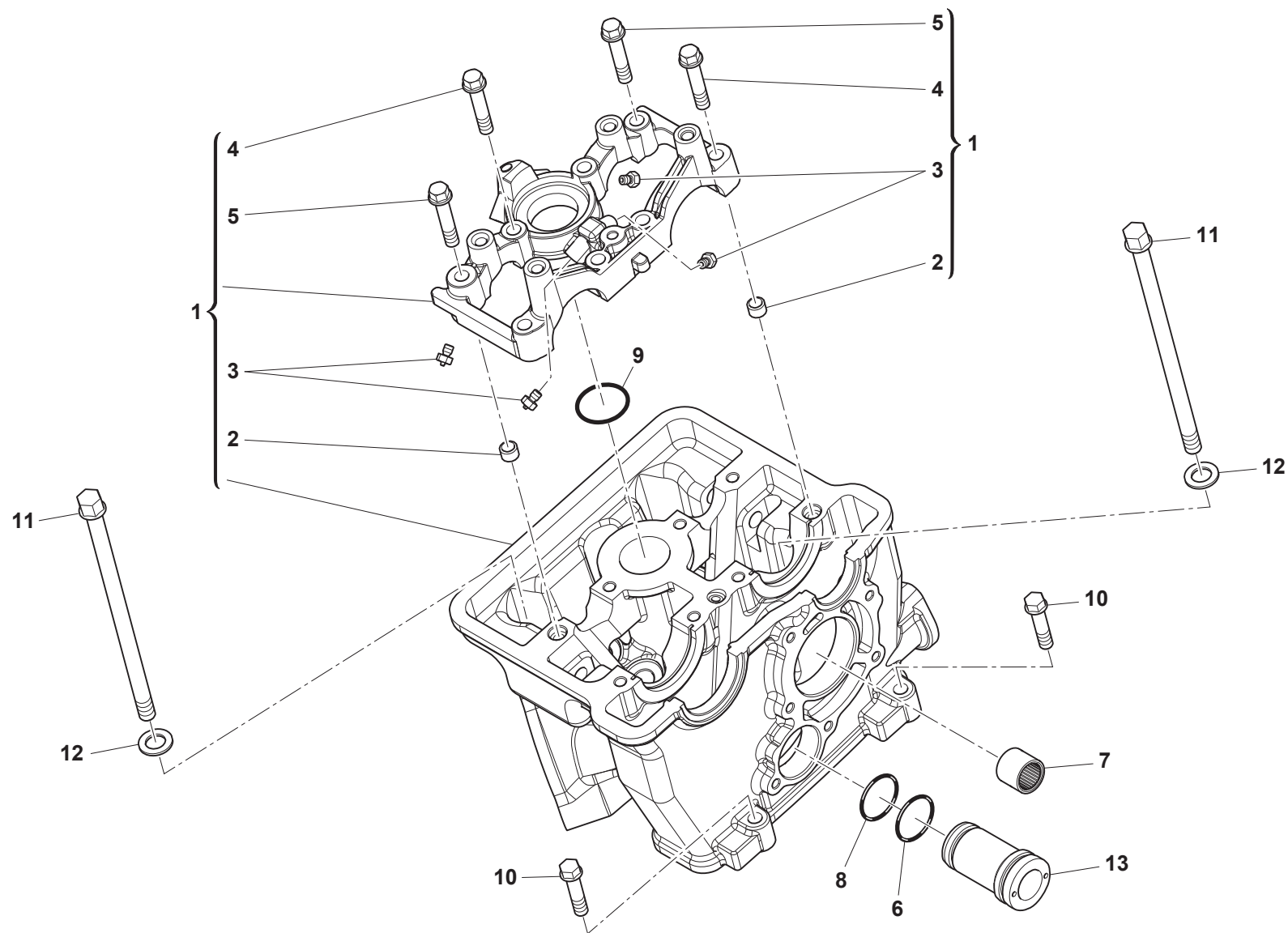

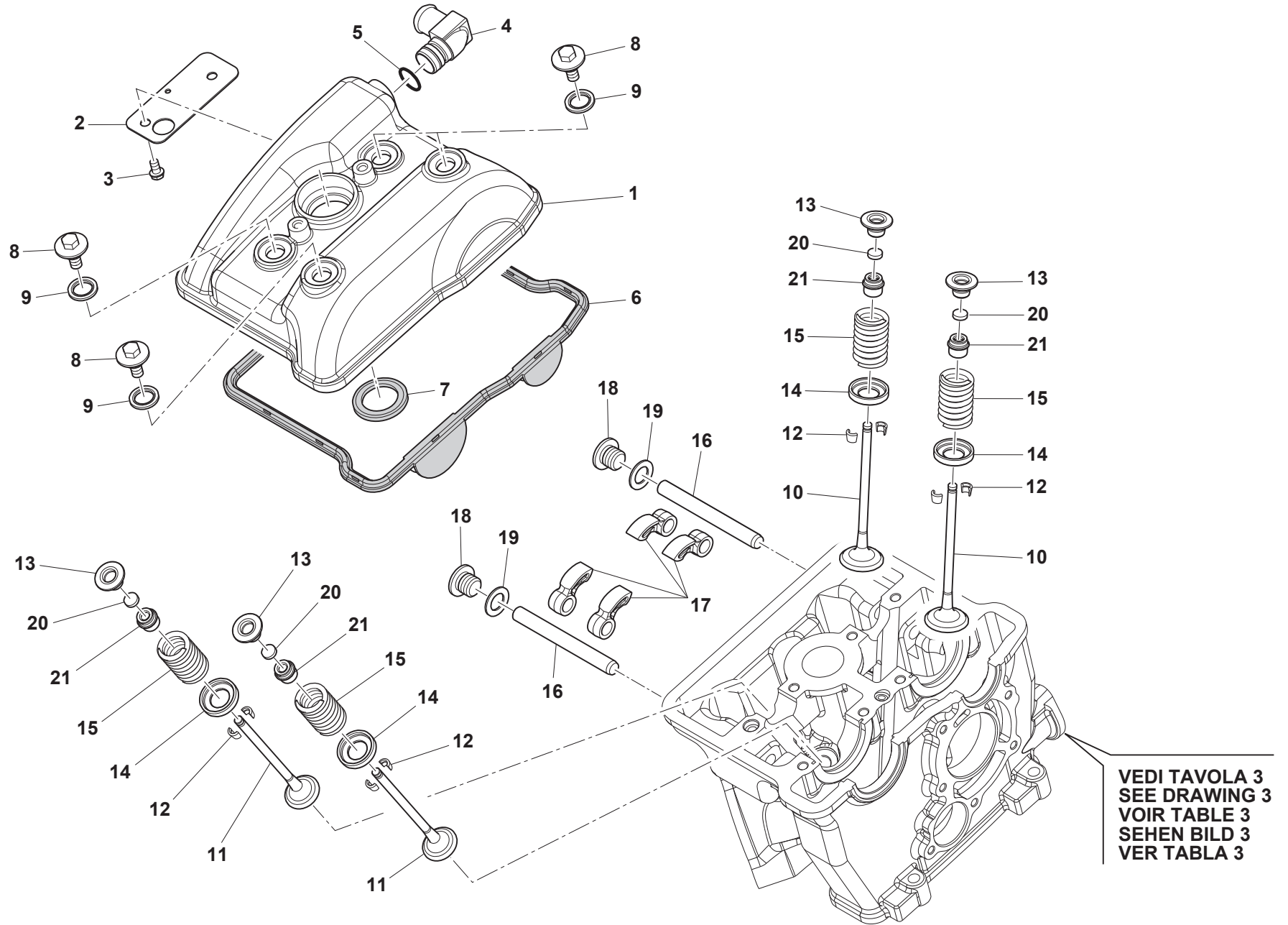

VEDI TAVOLA 3
SEE DRAWING 3
VOIR TABLE 3
SEHEN BILD 3
VER TABLA 3



RS 125R/2017
SM 125R/2017

COPERCHIO VALVOLE - VALVE COVER
COUVERCLE CULASSE - ZYLINDERKOPFDECKEL
TAPA CULATA

TAVOLA
DRAWING
TABLE
BILD
TABLA

4

Note Notes Marke Notas	Pos. No. Index Pos.	N. Cod. Code No. Nr. Code Code Nr N. Cod.	Q.tà Q.ty Q.te M.ge C.ad	DENOMINAZIONE	NAME	DESIGNATION	BESHREIBUNG	DENOMINACION
	1	22150284	1	COPERCHIO TESTA	HEAD COVER	COUVERCLE CULASSE	ZYLINDERKOPFDECKEL	TAPA CULATA
	2	73131648	1	PIASTRA BLOW BY	BLOW-BY PLATE	PLAQUE BLOW-BY	BLOW-BY PLATTE	PLACA BLOW-BY
	3	72012186	2	VITE TE M5x10	SCREW TE M5x10	VIS TE M5x10	SCHRAUBE TE M5x10	TORNILLO TC M6x12
	4	11050035	1	RACCORDO SFIATO	BREATHER PIPE FITTING	RACCORD RENIFLARD	ENTLÜFTUNGSANSCHLUSS	RACOR RESPIRADERO
	5	72150213	1	ANELLO OR	O-RING	JOINT TORIQUE	O-RING	JUNTA TORICA
	6	72150230	1	GUARNIZIONE COPERCHIO TESTA	HEAD COVER GASKET	JOINT COUVERCLE CULASSE	DICHTUNG ZYLINDERKOPFDECKEL	JUNTA TAPA CULATA
	7	72150233	1	GOMMINO	RUBBER RING	JOINT EN CAOUTCHOUC	GUMMSCHEIBE	GOMA
	8	72012182	4	VITE	BOLT	VIS	SCHRAUBE	TORNILLO
	9	73012547	4	RONDELLA GM2000	GM2000 WASHER	RONDELLE GM2000	UNTERLEGSSCHEIBE GM2000	ARANDELA
	10	22020098	2	VALVOLA DI ASPIRAZIONE	INTAKE VALVE	SOUPAPE D'ADMISSION	EINLASSVENTIL	VÁLVULA DE ADMISIÓN
	11	22020099	2	VALVOLA DI SCARICO	EXHAUST VALVE	SOUPAPE D'ÉCHAPPEMENT	AUSLASSVENTIL	VÁLVULA DE ESCAPE
	12	22040010	8	SEMICONO	COLLET	DEMI-CONE	KEGELHÄLFTE	SEMICONO
	13	22030022	4	SCODELLINO	RETAINER	RONDELLE A RESSORT	FEDERTELLER	ASIENTO
	14	22030023	4	PIATTELLO	PLATE	PLATEAU	FEDERTELLER	PLATO
	15	72120165	4	MOLLA PER VALVOLA	VALVE SPRING	RESSORT POUR SOUPAPE	FEDER FÜR VENTIL	MUELLE PARA VALVULA
	16	22070033	2	PERNO	PIN	AXE	BOLZEN	EJE
	17	22050045	4	BILANCIERE	ROCKER ARM	CULBUTEUR	UMLENK-HEBEL	BALANCÍN
	18	72012177	2	TAPPO	PLUG	BOUCHON	STOPFEN	TAPON
	19	72040667	2	ROSETTA	WASHER	RONDELLE	UNTERLEGSSCHEIBE	ARANDELA
	20	22020100	4	PASTIGLIA VALVOLA 1,2 mm - 2,4 mm	1,2 mm - 2,4 mm PAD, VALVE ADJUSTING	PASTILLE REGLAGE CULBETEUR 1,2 mm - 2,4 mm	VENTILKAEPPCHEN 1,2 mm - 2,4 mm	REGISTRO BALANCIN 1,2 mm - 2,4 mm
	21	72110237	4	TENUTA VALVOLE	VALVE SEALING	D'ETANCHEITE SOUPAPES	VENTILDICHTUNGS	ESTANQUEIDAD VALVULAS Ø5

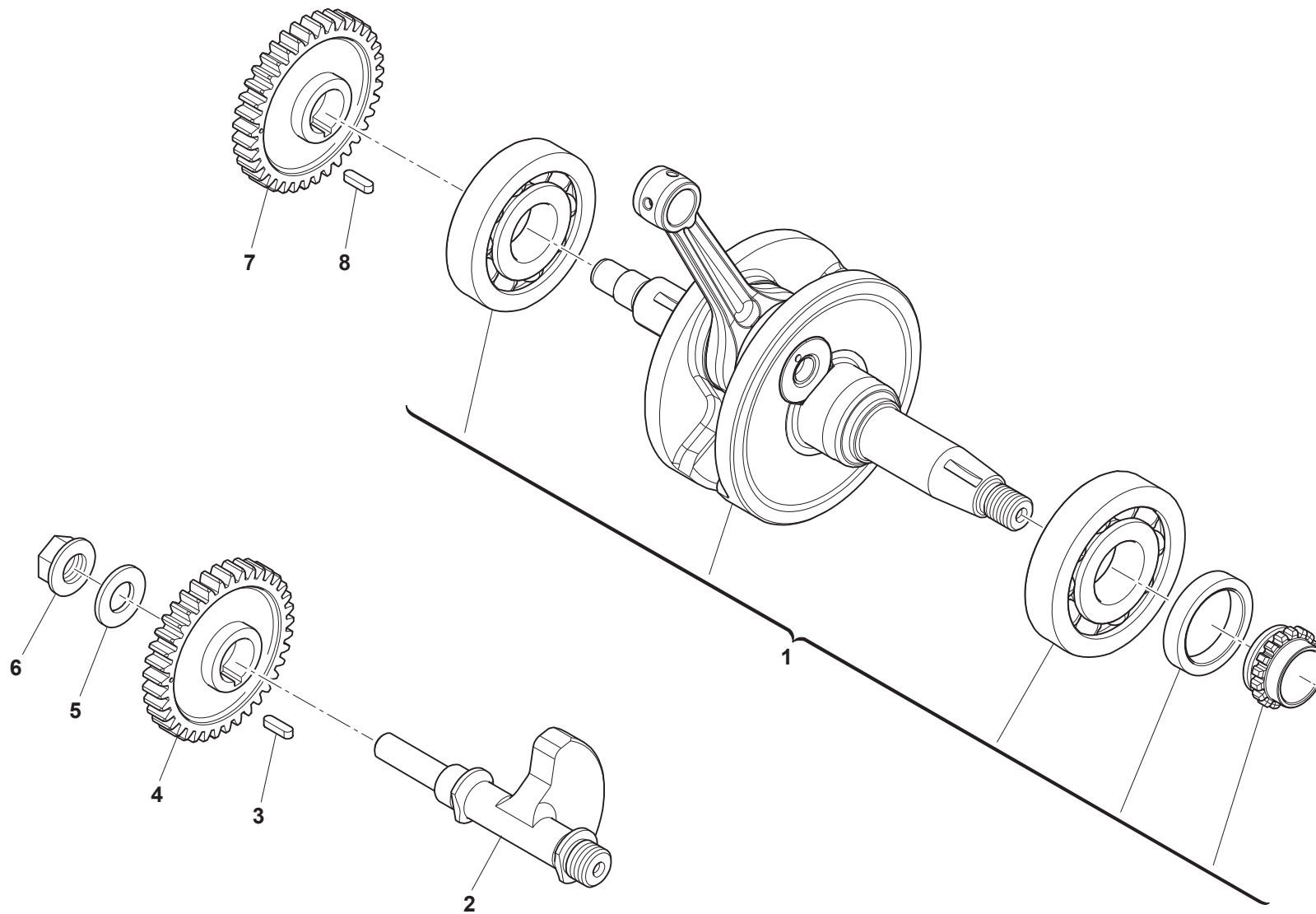

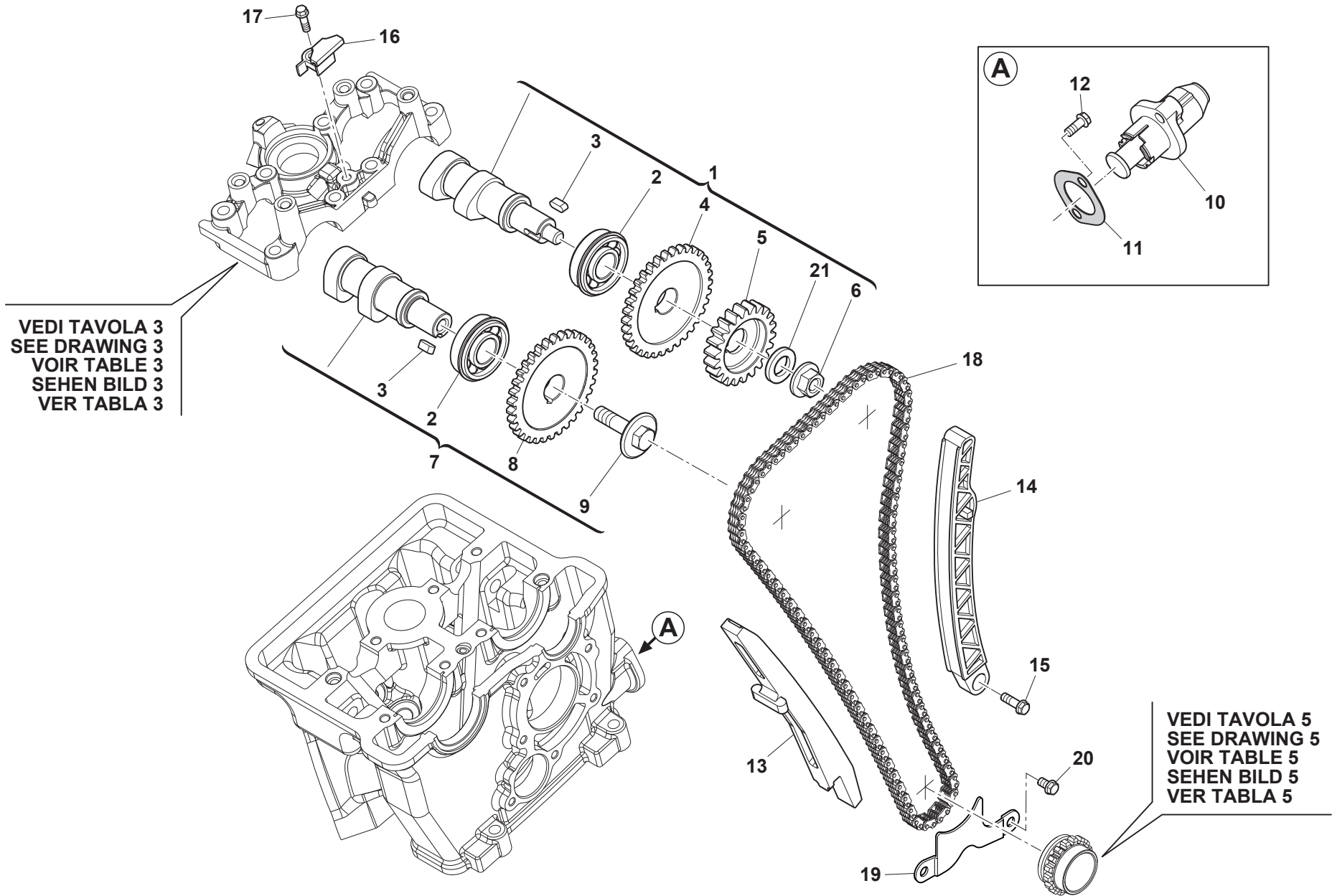



RS 125R/2017
SM 125R/2017

DISTRIBUZIONE - VALVE TIMING
DISTRIBUTION - VENTILSTEUERUNG
DISTRIBUCION

TAVOLA
DRAWING
TABLE
BILD
TABLA

6

Note Notes Notes Marke Notas	Pos. No. Index Pos.	N. Cod. Code No. Nr. Code Code Nr N. Cod.	Q.tà Q.ty Q.te M.ge C.ad	DENOMINAZIONE	NAME	DESIGNATION	BESHREIBUNG	DENOMINACION
	1	76220003	1	ALBERO A CAMME ASPIRAZIONE	INTAKE CAMSHAFT	ARBRE A CAMES ADMISSION	NOCKENWELLE EINLASS	ARBOL DE LEVAS ADMISIÓN
	2	22190019	2	CUSCINETTO RADIALE 6202NR	RADIAL BEARING 6202NR	ROULEMENT RADIAL 6202NR	RADIALLAGER 6202NR	COJINETE RADIAL 6202NR
	3	21210012	2	LINGUETTA	TAB	LANGUETTE	FEDERKEIL	LENGÜETA
	4	15170125	1	INGRANAGGIO CONDOTTO	DRIVEN GEAR	ENGRENAGE CONDUIT	ANGETRIEBENES ZAHNRAD	ENGRANAJE CONDUCIDO
	5	17010012	1	INGRANAGGIO POMPA	PUMP GEAR	ENGRENAGE POMPE	PUMPENZAHNRAD	ENGRANAJE BOMBA
	6	72020544	1	DADO FLANGIATO M8	FLANGED NUT M8	ECROU BRIDE M8	FLANSCHMUTTER M8	TUERCA CON BRIDA M8
	7	76220004	1	ALBERO A CAMME SCARICO	EXHAUST CAMSHAFT	ARBRE A CAMES ECHAPPEMENT	NOCKENWELLE AUSLASS	ARBOL DE LEVAS ESCAPE
	8	15170126	1	INGRANAGGIO CONDOTTO	DRIVEN GEAR	ENGRENAGE CONDUIT	ANGETRIEBENES ZAHNRAD	ENGRANAJE CONDUCIDO
	9	72012176	1	VITE SPECIALE M8x30	M8x30 SPECIAL BOLT	VIS SPÉCIAUX M8x30	SPEZIALSCHRAUBE M8x30	TORNILLO ESPECIAL M8x30
	10	8000A6950	1	TENDICATENA COMPLETO	COMPLETE CHAIN TENSIONER	TENDEUR DE CHAÎNE COMPLET	KETTENSANNER KOMPLETT	SENSOR DE CADENA COMPLETO
	11	8000A6954	1	GUARNIZIONE	GASKET	JOINT	DICHTUNG	JUNTA
	12	72010163	2	VITE TEF M6x25	FLANGED EXAGON HEAD SCREW M6x25	BOULON DE BRIDE M6x25	FLANSCHENSCHRAUBE M6x25	TORNILLO DE REBORDE M6x25
	13	73012518	1	PATTINO FISSO	FIXED SLIDER	PATIN FIXE	FESTE KETTENSANNERAUFLAGE	PATÍN FIJO
	14	73012517	1	PATTINO MOBILE	MOVING SLIDER	PATIN MOBILE	BEWEGLICHE KETTENSANNERAUFLAGE	PATÍN MÓVIL
	15	72012183	1	VITE	BOLT	VIS	SCHRAUBE	TORNILLO
	16	73012519	1	PATTINO	SLIDER	PATIN	SPANNERAUFLAGE	PATÍN
	17	72010157	1	VITE TEF M6x16	FLANGED EXAGON HEAD SCREW M6x16	BOULON DE BRIDE M6x16	FLANSCHENSCHRAUBE M6x16	TORNILLO DE REBORDE M6x16
	18	15160047	1	CATENA DISTRIBUZIONE (122 MAGLIE)	TIMING CHAIN (122 LINKS)	CHAÎNE DE DISTRIBUTION (122 MAILLONS)	VENTILSTEUERKETTE (122 GLIEDER)	CADENA DISTRIBUCION (122 ESLABONES)
	19	73131547	1	PIASTRA GUIDACATENA DISTRIBUZIONE	TIMING CHAIN GUIDE PLATE	PLAQUE GUIDE DE CHAÎNE DISTRIBUTION	PLATTE KETTENFÜHRUNG VENTILSTEUER	PLACA GUÍA CADENA DISTRIBUCION
	20	72010157	1	VITE TEF M6x16	FLANGED EXAGON HEAD SCREW M6x16	BOULON DE BRIDE M6x16	FLANSCHENSCHRAUBE M6x16	TORNILLO DE REBORDE M6x16
	21	72040431	1	ROSETTA PIANA IN ACCIAIO 8x20x2	IRON FLAT WASHER 8x20x2	RONDELLE PLATE 8x20x2	FLACHE UNTERLEGSCHEIBE 8x20x2	ARANDELA PLANA 8x20x2

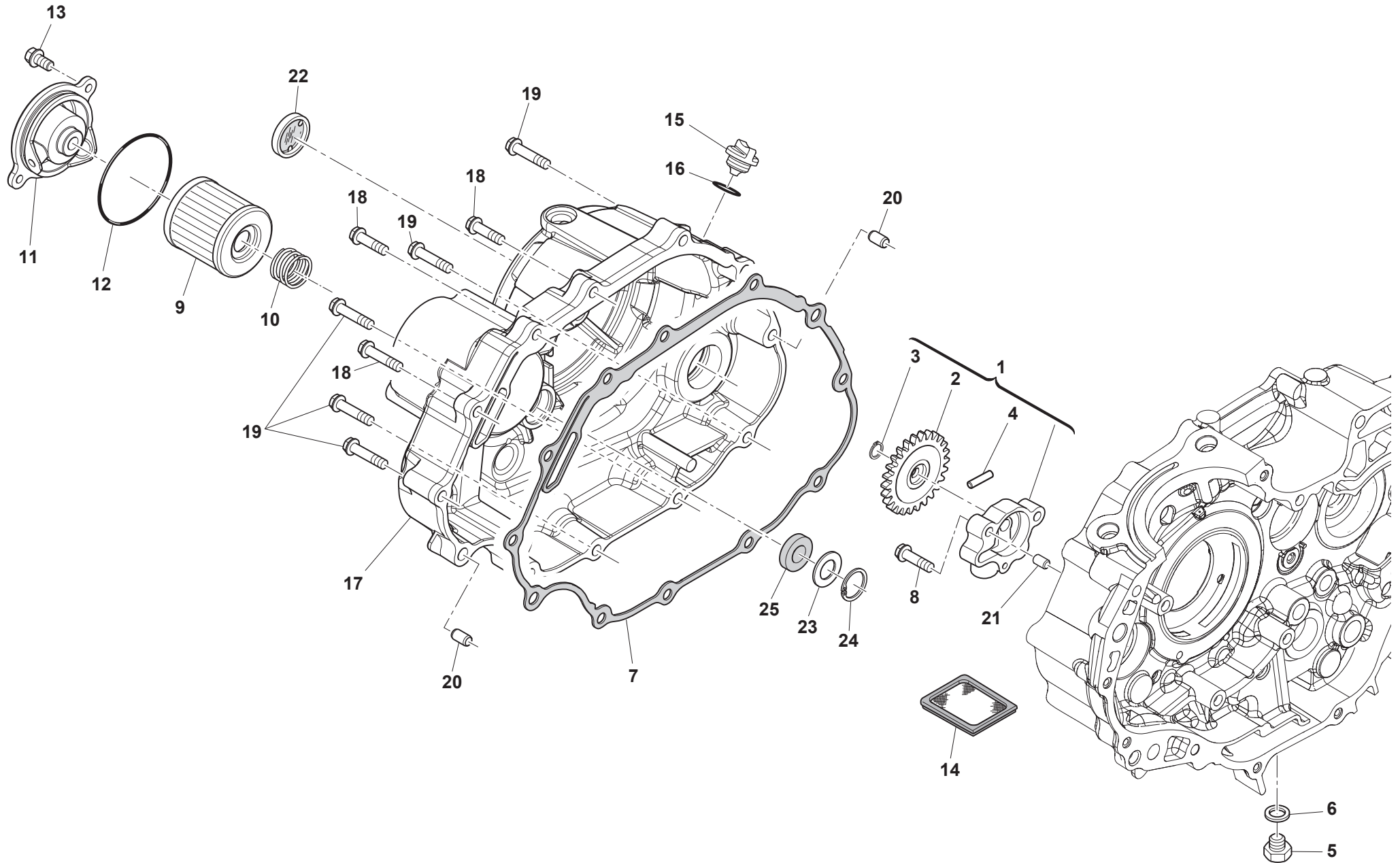



RS 125R/2017
SM 125R/2017

LUBRIFICAZIONE - LUBRIFICATION
GRAISSAGE - SCHMIERUNG
LUBRICACION

TAVOLA
DRAWING
TABLE
BILD
TABLA

7

Note Notes Marke Notas	Pos. No. N. Index Pos.	N. Cod. Code No. Nr. Code Code Nr N. Cod.	Q.tà Q.ty Q.te M.ge C.ad	DENOMINAZIONE	NAME	DESIGNATION	BESHREIBUNG	DENOMINACION
	1	20010078	1	POMPA OLIO COMPLETA	COMPLETE OIL PUMP	POMPE A HUILE COMPLETE	ÖLPUMPE KOMPLETT	BOMBA ACEITE COMPLETA
	2	20080022	1	INGRANAGGIO POMPA OLIO	OIL PUMP GEAR	ENGRENAGE POMPE	PUMPENZAHRAD	ENGRANAJE BOMBA
	3	20080024	1	ANELLO DI FERMO	RETAINING RING	BAGUE D'ARRET	SICHERUNGSRING	ANILLO DE RETENCION
	4	20080023	1	RULLINO Ø3x16	RØ3x16 OLLER	AIGUILLE Ø3x16	ROLLE Ø3x16	RODILLO Ø3x16
	5	72012089	1	TAPPO SCARICO OLIO	OIL DRAIN PLUG	BOUCHON VIDANGE D'HUILE	OLABLASSSCHRAUBE	TAPON VACIADO ACEITE
	6	72040159	1	ROSETTA	WASHER	RONDELLE	UNTERLEGSCHIEBE	ARANDELA
	7	72130623	1	GUARNIZIONE COPERCHIO FRIZIONE	GASKET	JOINT	DICHTUNG	JUNTA
	8	72010168	2	VITE TEF M6x30	FLANGED EXAGON HEAD SCREW M6x30	BOULON DE BRIDE M6x30	SCHRAUBE M6x30	TORNILLO M6x30
	9	20030030	1	FILTRO OLIO A CARTUCCIA	OIL CARTRIDGE FILTER	FILTRE À HUILE À CARTOUCHE	PATRONEN-ÖLFILTER	FILTRO ACEITE DE CARTUCHO
	10	72120166	1	MOLLA PREMI FILTRO-CARTUCCIA	FILTER/CARTRIDGE PRESSING SPRING	RESSORT PRESSE FILTRE-CARTOUCHE	DRUCKFEDER FILTER-PATRONE	MUELLE PRENSA FILTRO-CARTUCHO
	11	14090081	1	COPERCHIO FILTRO OLIO	OIL FILTER COVER	COUVERCLE	DECKEL	TAPA
	12	72150237	1	ANELLO OR	O-RING	JOINT TORIQUE	O-RING	JUNTA TORICA
	13	72010157	2	VITE M6x16	SCREW M6x16	VIS M6x16	SCHRAUBE M6x16	TORNILLO M6x16
	14	11060002	1	FILTRO A RETE	MESH FILTER	FILTRE À GRILLE	NETZFILTER	FILTRO DE RED
	15	73010450	1	TAPPO CARICO OLIO	OIL FILLER PLUG	BOUCHON DE REMPLISSAGE HUILE	ÖLEINFÜLLSCHRAUBE	TAPON LLENADO ACEITE
	16	72150018	1	ANELLO OR	O-RING	JOINT TORIQUE	O-RING	JUNTA TORICA
	17	13011978	1	COPERCHIO FRIZIONE	CLUTCH COVER	COUVERCLE D'EMBRAYAGE	KUPPLUNGSDECKEL	TAPA EMBRAGUE
	18	72010387	3	VITE TEF M6x28	FLANGED EXAGON HEAD SCREW M6x28	BOULON DE BRIDE M6x28	FLANSCHENSCHRAUBE M6x28	TORNILLO DE REBORDE M6x28
	19	72010389	9	VITE TEF M6x40	FLANGED EXAGON HEAD SCREW M6x40	BOULON DE BRIDE M6x40	SCHRAUBE M6x40	TORNILLO M6x40
	20	72060012	2	BUSSOLA	BUSHING	DOUILLE	BUCHSE	CASQUILLO
	21	72060013	2	BUSSOLA	BUSHING	DOUILLE	BUCHSE	CASQUILLO
	22	800073529	1	OBLÒ PER LIVELLO OLIO	OIL LEVEL INSPECTION SIGHT GLASS	HUBLOT DE CONTRÔLE NIVEAU D'HUILE	SCHAUGLAS FÜR ÖLSTAND	MIRILLA PARA NIVEL ACEITE
	23	72040677	1	ROSETTA	WASHER	RONDELLE	UNTERLEGSCHIEBE	ARANDELA
	24	72080073	1	ANELLO ELASTICO	CIRCLIP	CIRCLIP	SPRENGRING	ANILLO ELASTICO
	25	72110169	1	ANELLO DI TENUTA Ø12xØ18x5	Ø12xØ18x5 SEALING RING	BAGUE D'ETANCHEITE Ø12xØ18x5	DICHTUNGSRING Ø12xØ18x5	ANILLO DE ESTANQUEIDAD Ø12xØ18x5

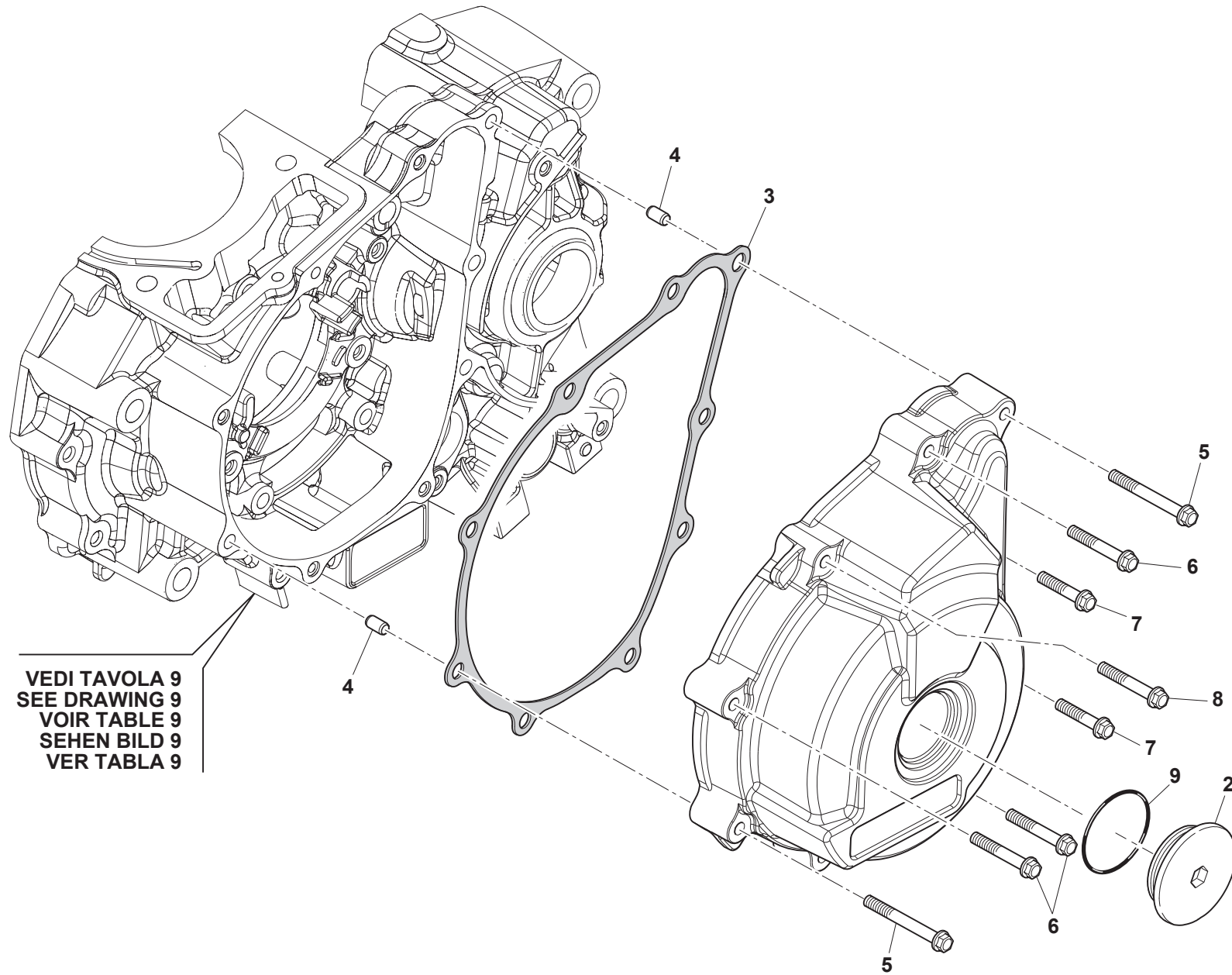

VEDI TAVOLA 9
SEE DRAWING 9
VOIR TABLE 9
SEHEN BILD 9
VER TABLA 9

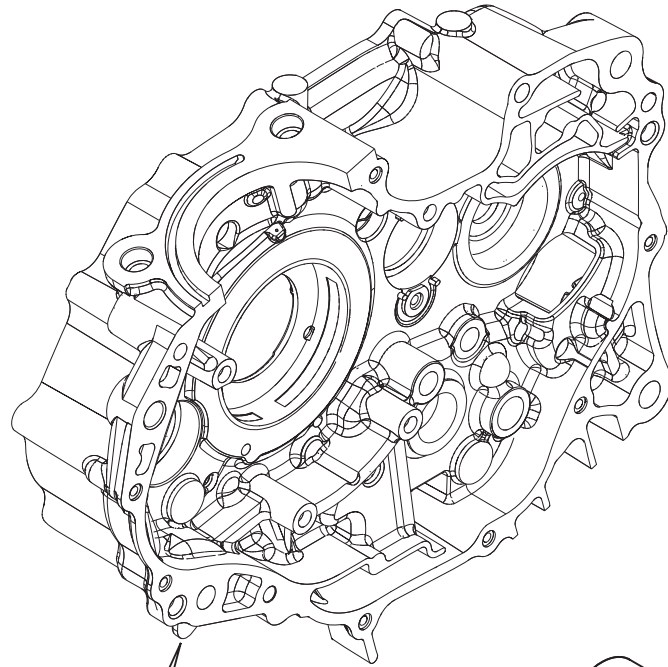

VEDI TAVOLA 10
SEE DRAWING 10
VOIR TABLE 10
SEHEN BILD 10
VER TABLA 10

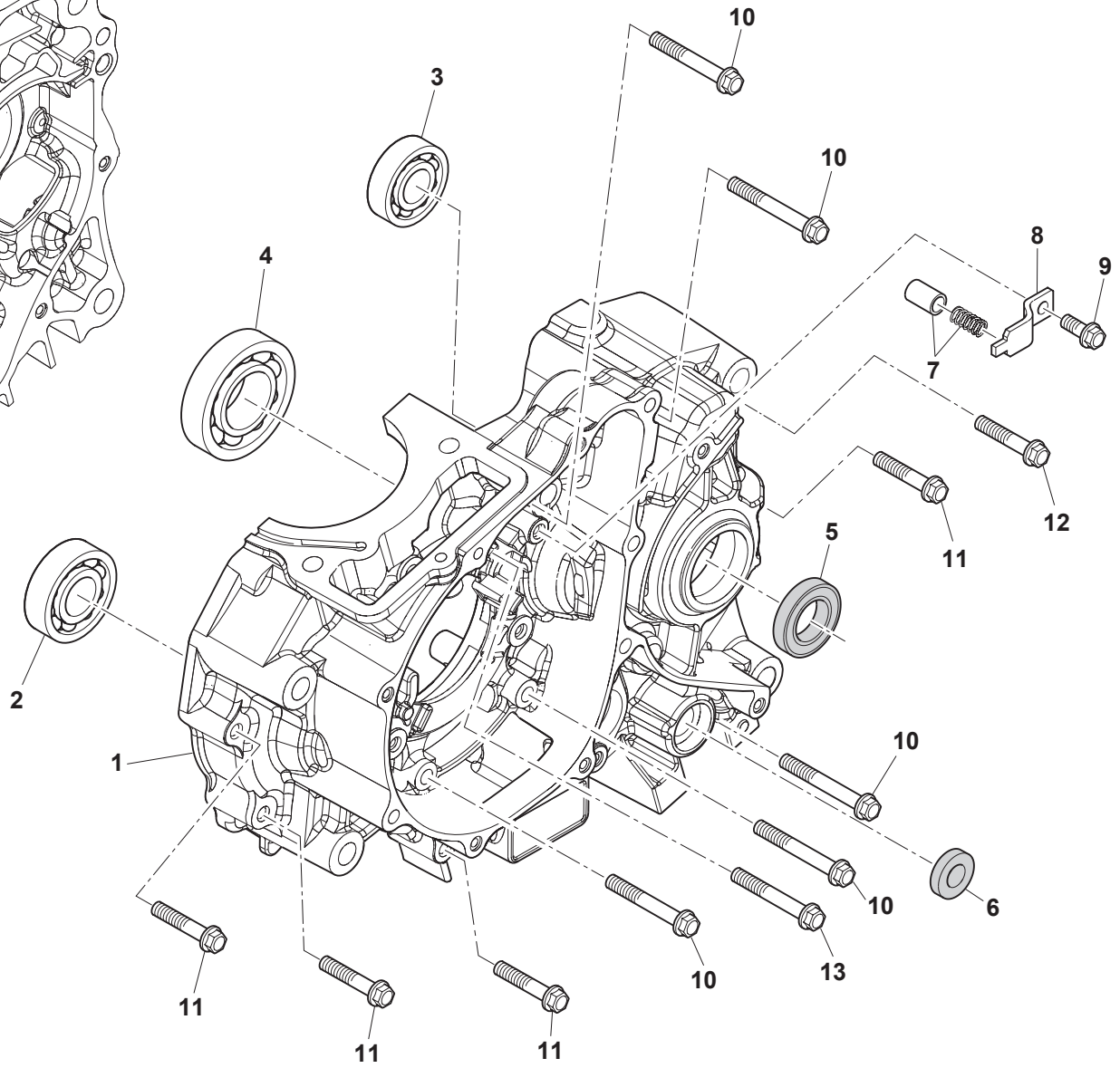

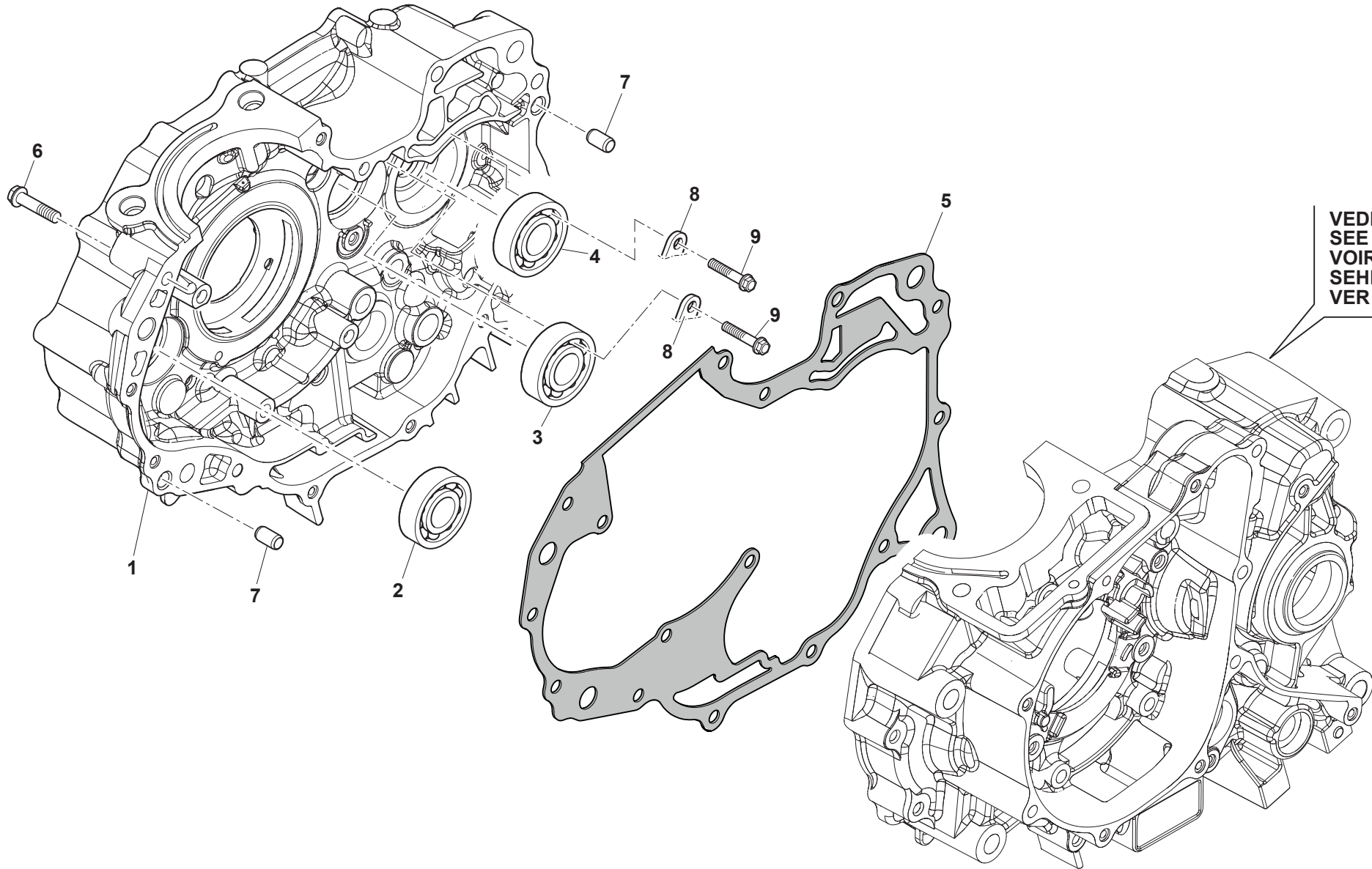

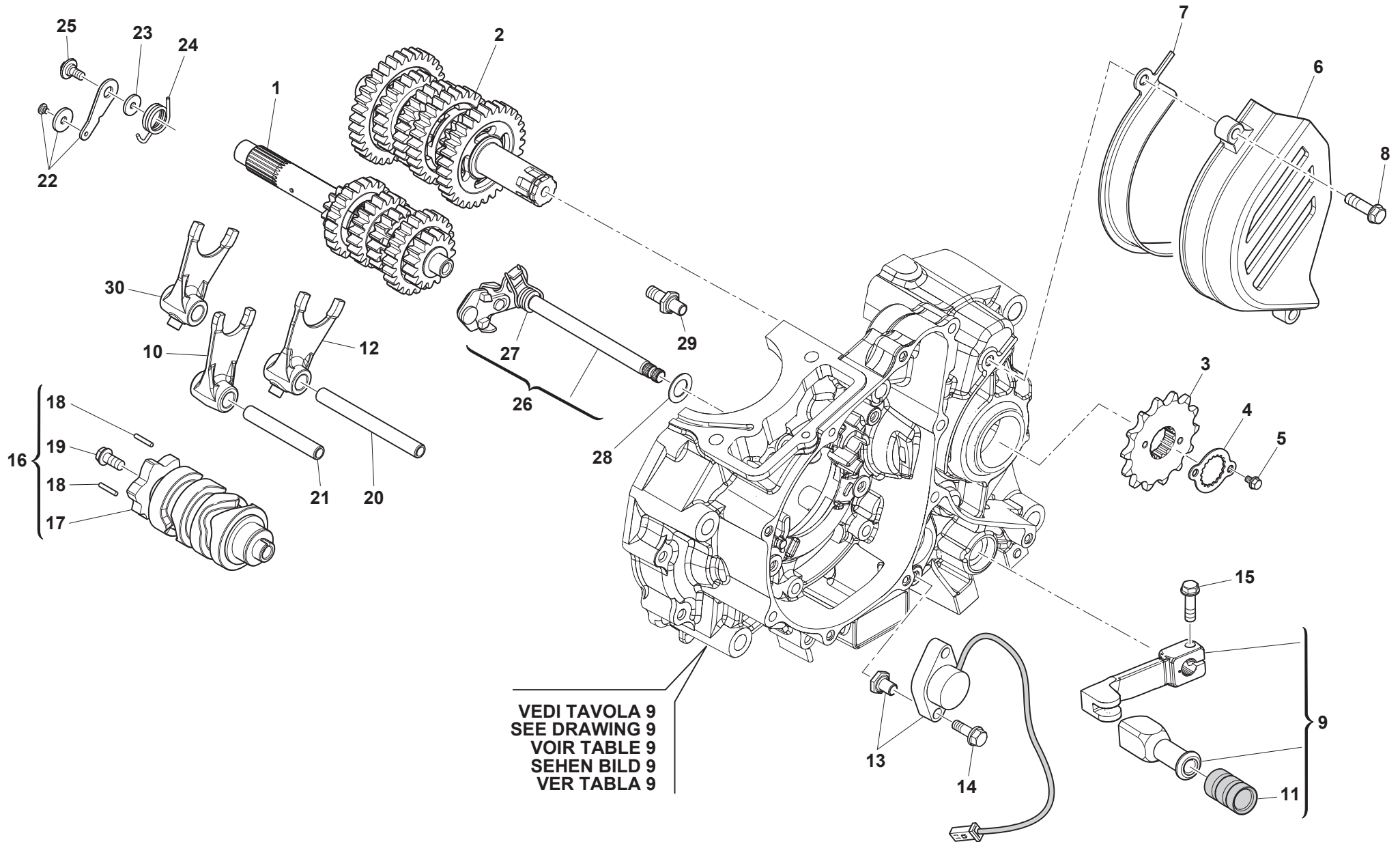



RS 125R/2017
SM 125R/2017

COMANDO CAMBIO - GEARSHIFT MECHANISM
COMMANDE DE VITESSE - GANGSCHALTUNG
MANDO CAMBIO

TAVOLA
DRAWING
TABLE
BILD
TABLA

12

Note Notes Marke Notas	Pos. No. N. Index Pos.	N. Cod. Code No. Nr. Code Code Nr N. Cod.	Q.tà Q.ty Q.te M.ge C.ad	DENOMINAZIONE	NAME	DESIGNATION	BESHREIBUNG	DENOMINACION
	1	15020130	1	ASSIEME ALBERO PRIMARIO	INPUT SHAFT ASSY	ARBRE PRIMAIRE COMPL.	ZUSAMMENBAU HAUPTANTRIEBSWELLE	CONJUNTO ARBOL PRIMARIO
	2	15030170	1	ASSIEME ALBERO SECONDARIO	OUTPUT SHAFT ASSY	ARBRE SECONDAIRE COMPL.	ZUSAMMENBAU VORGELEGEWELLE	CONJUNTO ARBOL SECONDARIO
	3	15170128	1	PIGNONE USCITA CAMBIO Z=14	TRANSMISSION SPROCKET T=14	PIGNON SORTIE BOÎTE DE VITESSES Z=14	GETRIEBE-AUSGANGSRITZEL Z=14	PINON SALIDA CAMBIO Z=14
	4	73130522	1	PIASTRA FISSAGGIO PIGNONE	PINION FIXING BRACKET	PLAQUE PIGNON	RITZELPLATTE	PLACA PINON
	5	72010089	2	VITE M6x10	M6x10 BOLT	VIS M6x10	SCHRAUBE M6x10	TORNILLO M6x10
	6	M000P00335	1	COPERCHIO PIGNONE CATENA	CHAIN SPROCKET COVER	COUVERCLE PIGNON CHAÎNE	DECKEL KETTENRITZEL	TAPA PINON CADENA
	7	M000P00336	1	PIASTRINA	PLATE	PLAQUETTE	PLÄTTCHEN	PLACA
	8	Z00062728	2	VITE TEF M6x20	FLANGED EXAGON HEAD SCREW M6x20	BOULON DE BRIDE M6x20	SCHRAUBE M6x20	TORNILLO M6x20
	9	M000A01432	1	ASS. LEVA COMANDO CAMBIO	GEAR CONTROL LEVER ASSY	LEVIER DE COM. BOÎTE DE VITESSES COMPL.	ZSB. SCHALTABEL	CONJ. PALANCA MANDO CAMBIO
	10	15140055	1	FORCELLA INGRANAGGIO 5ª E 6ª VELOCITÀ	5TH AND 6TH GEAR FORK	FOURCHE PIGNON 5ÈME ET 6ÈME	GABEL ZAHNRAD 5. UND 6. GANG	HORQUILLA ENGRANAJE 5ª Y 6ª VEL.
	11	F000P01351	1	GOMMINO	RUBBER RING	JOINT EN CAOUTCHOUC	GUMMISCHEIBE	GOMA
	12	15140053	1	FORCELLA INGRANAGGIO 2ª E 3ª VELOCITÀ	2ND AND 3RD GEAR FORK	FOURCHE PIGNON 2ÈME ET 3ÈME	GABEL ZAHNRAD 2. UND 3. GANG	HORQUILLA ENGRANAJE 2ª Y 3ª VEL.
	13	11040208	1	SENSORE FOLLE	NEUTRAL POSITION SWITCH	CAPTEUR POINT MORT	LEERLAUFSSENSOR	SENSOR PUNTO MUERTO
	14	72010163	2	VITE M6x25	BOLT M6x25	VIS M6x25	SCHRAUBE M6x25	TORNILLO M6x25
	15	Z00062728	1	VITE TEF M6x20	FLANGED EXAGON HEAD SCREW M6x20	BOULON DE BRIDE M6x20	SCHRAUBE M6x20	TORNILLO M6x20
	16	76220006	1	ALBERO COMANDO FORCELLE	SELECTOR SHAFT	ARBRE DE COMMANDE FOURCHES	SCHALTGABELWELLE	EJE MANDO HORQUILLAS
	17	15090014	1	TAMBURO SELETTORE MARCE	GEAR SELECTOR DRUM	TAMBOUR SELECTEUR DE VITESSES	SCHALTWALZE	TAMBOR SELECTOR MARCHAS
	18	15180039	2	PERNO	PIN	AXE	BOLZEN	EJE
	19	72010095	1	VITE M6x20	M6x20 BOLT	VIS M6x20	SCHRAUBE M6x20	TORNILLO M6x20
	20	15140041	1	PERNO FORCELLA	FORK PIN	AXE FOURCHE	BOLZEN GABEL	EJE HORQUILLA
	21	15140042	1	PERNO FORCELLA	FORK PIN	AXE FOURCHE	BOLZEN GABEL	EJE HORQUILLA
	22	15080023	1	PIASTRINA DI FERMO SELETTORE	SELECTOR LOCK PLATE	PLAQUETTE D'ARRET SELECTEUR	HALTEPLÄTTCHEN SCHALTWALZE	PLACA DE FIJACION SELECTOR
	23	72040676	1	ROSETTA	WASHER	RONDELLE	UNTERLEGSSCHEIBE	ARANDELA
	24	72120121	1	MOLLA	SPRING	RESSORT	FEDER	MUELLE
	25	72011366	1	VITE	BOLT	VIS	SCHRAUBE	TORNILLO
	26	15070072	1	ASSIEME ALBERO SELETTORE	SELECTOR SHAFT ASSY	ARBRE SELECTEUR COMPL.	ZUSAMMENBAU SCHALTWALZENWELLE	CONJUNTO ARBOL SELECTOR
	27	15130036	1	MOLLA	SPRING	RESSORT	FEDER	MUELLE
	28	15130037	1	ROSETTA	WASHER	RONDELLE	UNTERLEGSSCHEIBE	ARANDELA
	29	72011772	1	PERNO DI FERMO SELETTORE	SELECTOR LOCK PIN	AXE D'ARRET SELECTEUR	BLOCKIERVORRICHTUNG SCHALTWALZE	EJE DE RETENCION SELECTOR
	30	15140054	1	FORCELLA INGRANAGGIO 1ª E 4ª VELOCITÀ	1ST, 4TH GEAR FORK	FOURCHE PIGNON 1ÈRE, 4ÈME	GABEL ZAHNRAD 1. UND 4. GANG	HORQUILLA ENGRANAJE 1ª Y 4ª VEL.

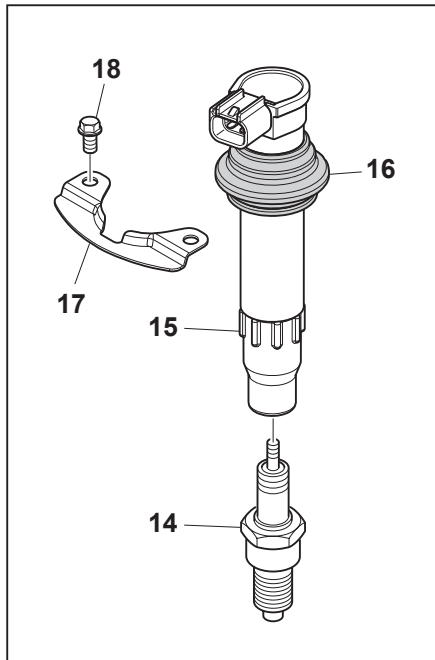
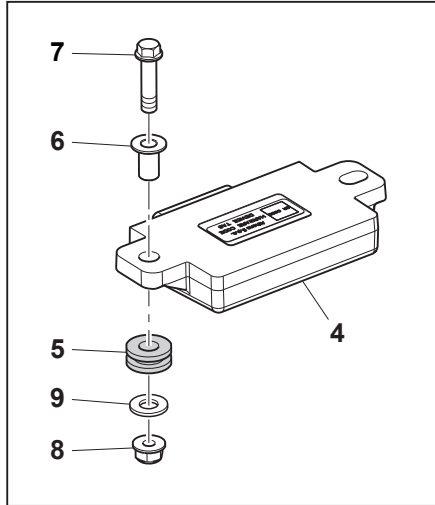

VEDI TAVOLA 14
SEE DRAWING 14
VOIR TABLE 14
SEHEN BILD 14
VER TABLA 14

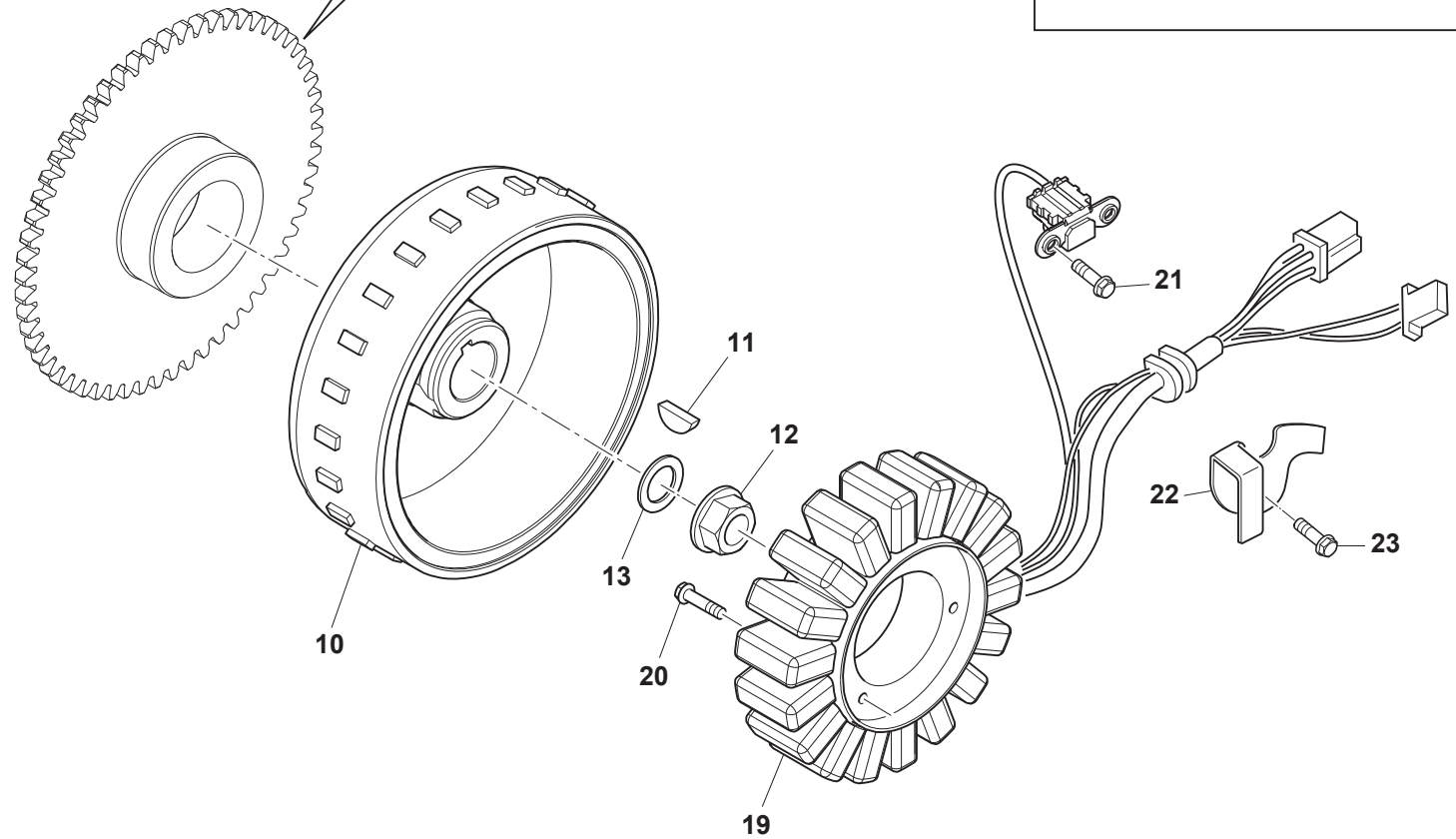
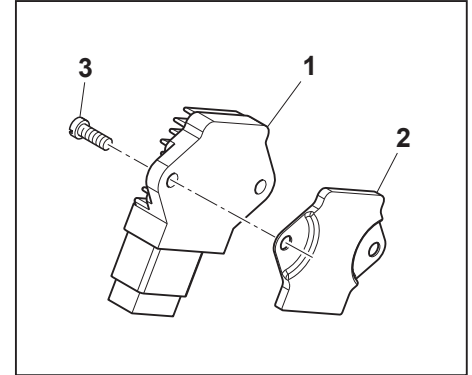



RS 125R/2017
SM 125R/2017

PARTE ELETTRICA - IGNITION SYSTEM
PARTIES ELECTRIQUE - ELEKTRISCHE TEILE
PARTE ELECTRICA

TAVOLA
DRAWING
TABLE
BILD
TABLA

13

Note Notes Notes Marke Notas	Pos. No. Index Pos.	N. Cod. Code No. Nr. Code Code Nr N. Cod.	Q.tà Q.ty Q.te M.ge C.ad	DENOMINAZIONE	NAME	DESIGNATION	BESHREIBUNG	DENOMINACION
	1	8000B0563	1	REGOLATORE DI TENSIONE	VOLTAGE REGULATOR	RÉGULATEUR DE TENSION	SPANNUNGSREGLER	REGULADOR DE TENSIÓN
	2	8000B1061	1	PIASTRINA DISSIPAZIONE CALORE	HEAT DISSIPATION PLATE	PLAQUETTE	PLÄTTCHEN	PLACA
	3	Z00062728	2	VITE TEF M6x20	FLANGED EXAGON HEAD SCREW M6x20	BOULON DE BRIDE M6x20	SCHRAUBE M6x20	TORNILLO M6x20
	4	E000A01653	1	CENTRALINA PROGRAMMATA	PROGRAMMED CONTROL UNIT	BOÏTIER	STEUEREL	CENTRALITA PROGRAMADA
	5	800041862	2	GOMMINO	RUBBER RING	JOINT EN CAOUTCHOUC	GUMMISCHEIBE	GOMA
	6	F000P01527	2	DISTANZIALE	SPACER	ENTRETOISE	ABSTANDHALTER	DISTANCIADOR
	7	Z00062729	2	VITE TEF M6x25	FLANGED EXAGON HEAD SCREW M6x25	BOULON DE BRIDE M6x25	FLANSCHENSCHRAUBE M6x25	TORNILLO DE REBORDE M6x25
	8	Z00044240	2	DADO	NUT	ECROU	MUTTER	TUERCA
	9	Z00048814	2	ROSETTA	WASHER	RONDELLE	UNTERLEGSSCHEIBE	ARANDELA
	10	31150168	1	ROTORE	ROTOR	ROTOR	ROTOR	ROTOR
	11	21210014	1	CHIAVETTA	WOODRUFF KEY	CLÉ	FEDERKEIL	MEMORIA
	12	72020426	1	DADO FLANGIATO	FLANGED NUT	ECROU BRIDE	FLANSCHMUTTER	TUERCA CON BRIDA
	13	720040463	1	ROSETTA	WASHER	RONDELLE	UNTERLEGSSCHEIBE	ARANDELA
	14	31170039	1	CANDELA NGK CR8E	SPARK PLUG NGK CR8E	BOUGIE NGK CR8E	ZÜNDKERZE NGK CR8E	BUJÍA NGK CR8E
	15	31020133	1	BOBINA	COIL	BOBINE	ZÜNDSPULE	BOBINA
	16	72150238	1	GOMMINO	RUBBER RING	JOINT EN CAOUTCHOUC	GUMMISCHEIBE	GOMA
	17	73131652	1	PIASTRINA	PLATE	PLAQUETTE	PLÄTTCHEN	PLACA
	18	72012186	2	VITE TEF M5x8	FLANGED EXAGON HEAD SCREW M5x8	BOULON DE BRIDE M5x8	FLANSCHENSCHRAUBE M5x8	TORNILLO DE REBORDE M5x8
	19	31140381	1	STATORE	STATOR	STATOR	STATOR	ESTATOR
	20	72010386	3	VITE TEF M6x22	FLANGED EXAGON HEAD SCREW M6x22	BOULON DE BRIDE M6x22	FLANSCHENSCHRAUBE M6x22	TORNILLO DE REBORDE M6x22
	21	72010157	2	VITE PICK UP M6x16	PICK UP M6x16 BOLT	VIS PICK UP M6x16	SCHRAUBE PICK UP M6x16	TORNILLO PICK UP M6x16
	22	73131651	1	PIASTRINA	PLATE	PLAQUETTE	PLÄTTCHEN	PLACA
	23	72010157	1	VITE M6x16	SCREW M6x16	VIS M6x16	SCHRAUBE M6x16	TORNILLO M6x16

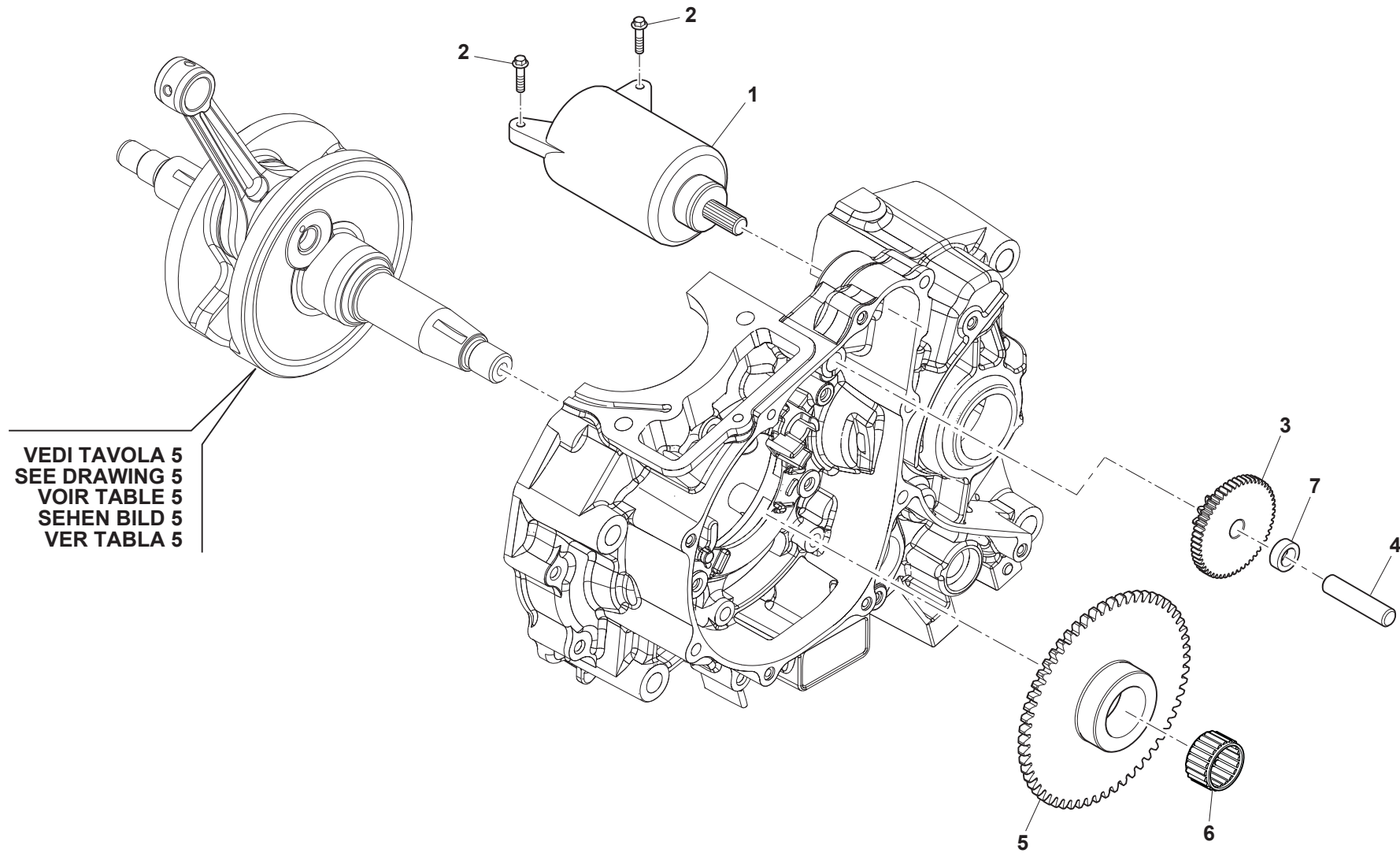

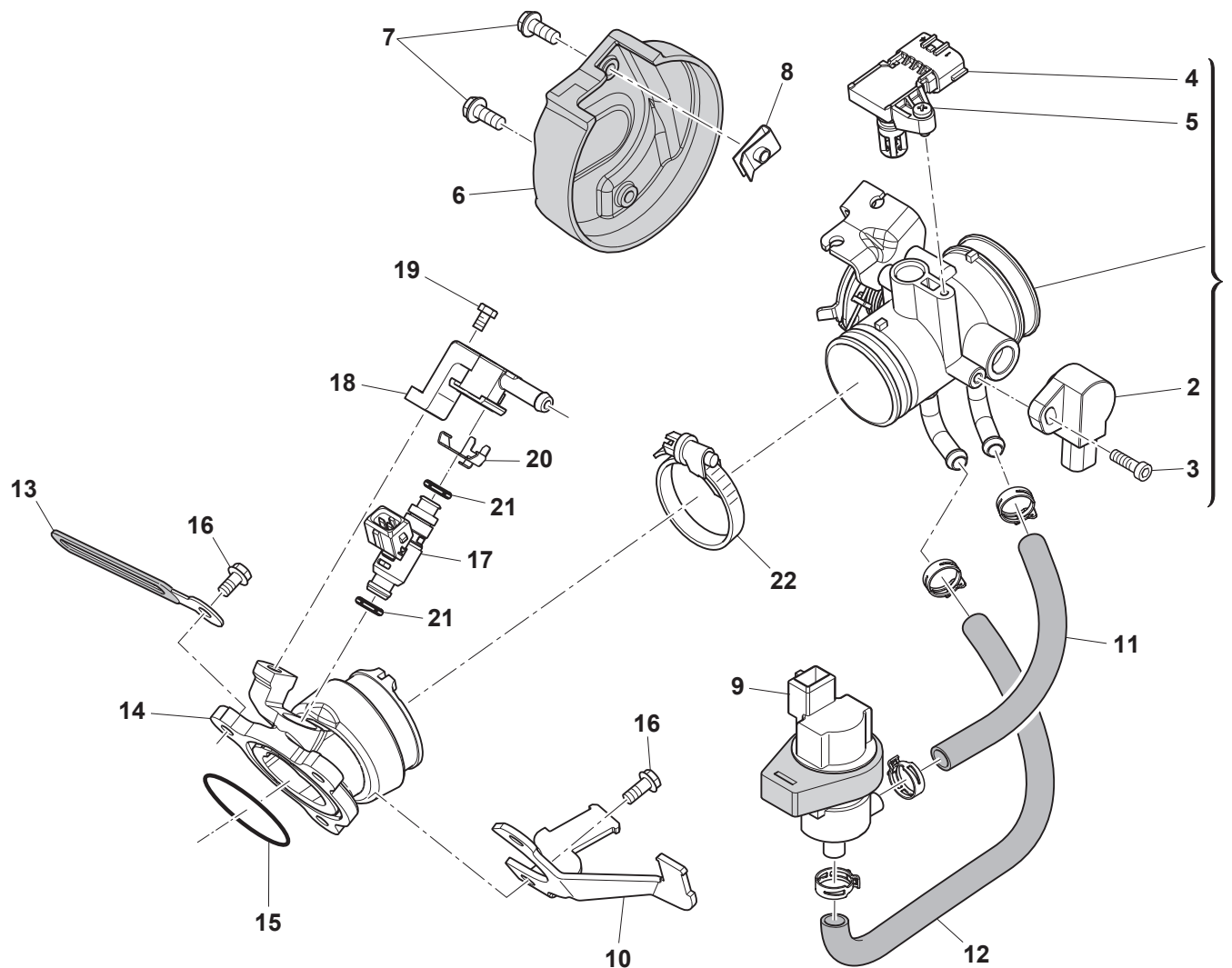



RS 125R/2017
SM 125R/2017

CORPO FARFALLATO - THROTTLE BODY
CORP PAPILLON - DROSSELKLAPPENKÖRPER
CUERPO OSCILANTE

TAVOLA
DRAWING
TABLE
BILD
TABLA

15

Note Notes Notes Marke Notas	Pos. No. N. Index Pos.	N. Cod. Code No. Nr. Code Code Nr N. Cod.	Q.tà Q.ty Q.te M.ge C.ad	DENOMINAZIONE	NAME	DESIGNATION	BESHREIBUNG	DENOMINACION
	1	M000A00895	1	ASSIEME CORPO FARFALLATO	THROTTLE BODY ASSY	CORPS À PAPILLONS	DROSSELKÖRPER	CUERPO MARIPOSA
	2	31350080	1	SENSORE DI POSIZIONE	POSITION SENSOR	CAPTEUR	SENSOR	SENSOR
	3	72030657	1	VIITE TCIC M4x16	TCIC M4x16 BOLT	VIS TCIC M4x16	SCHRAUBE TCIC M4x16	TORNILLO TCIC M4x16
	4	31350057	1	SENSORE DI PRESSIONE	PRESSURE SENSOR	CAPTEUR DE PRESSION	DRUCKSENSOR	SENSOR PRESIÓN
	5	72030078	1	VITE TEF M5x12	FLANGED EXAGON HEAD SCREW M5x12	BOULON DE BRIDE M5x12	FLANSCHENSCHRAUBE M5x12	TORNILLO DE REBORDE M5x12
	6	F000P00855	1	COPERCHIO	COVER	COUVERCLE	DECKEL	TAPA
	7	Z00067997	2	VITE TEF M5x12	FLANGED EXAGON HEAD SCREW M5x12	BOULON DE BRIDE M5x12	FLANSCHENSCHRAUBE M5x12	TORNILLO DE REBORDE M5x12
	8	8000H2168	1	DADO A GRAFFETTA M5	CLIP NUT M5	ECROU À AGRAFE M5	SICHERUNGSMUTTER M5	TUERCA DE CLIP M5
	9	31350058	1	VALVOLA SOLENOIDE	SOLENOID VALVE	VANNE À SOLÉNOÏDE	MAGNETVENTIL	VÁLVULA SOLENOIDE
	10	F000P01524	1	SUPPORTO VALVOLA SOLENOIDE	SOLENOID VALVE BRACKET	SUPPORT	HALTERUNG	SOPORTE
	11	73090282	1	TUBO INGRESSO	INTAKE HOSE	TUYAU DE REFOULEMENT	VORLAUFROHR	TUBO ALIMENTACIÓN
	12	73090283	1	TUBO USCITA	OUTLET HOSE	TUYAU DE SORTIE	ANSCHLUSSROHR	TUBO SALIDA
	13	8000A1792	1	FASCETTA	CLAMP	COLLIER	SHELLE	ABRAZADERA
	14	M000P00734	1	RACCORDO CORPO FARFALLATO	THROTTLE BODY UNION	RACCORD CORPS À PAPILLONS	ANSCHLUSS DROSSELKÖRPER	RACOR CUERPO DE MARIPOSA
	15	M000P01454	1	ANELLO OR	O-RING	JOINT TORIQUE	O-RING	JUNTA TORICA
	16	Z00062728	3	VITE TEF M6x20	FLANGED EXAGON HEAD SCREW M6x20	BOULON DE BRIDE M6x20	SCHRAUBE M6x20	TORNILLO M6x20
	17	F000P00850	1	INIETTORE	INJECTOR	INJECTEUR	EINSPRITZDÜSE	INYECTOR
	18	F000P00851	1	CAPPUCCIO INIETTORE	INJECTOR CAP	CAPUCHON	KAPPE	CAPUCHÓN
	19	Z00062726	1	VITE TEF M6x14	FLANGED EXAGON HEAD SCREW M6x14	BOULON DE BRIDE M6x14	FLANSCHENSCHRAUBE M6x14	TORNILLO DE REBORDE M6x14
	20	F000P00852	1	CLIP	CLIP	COLLIER	SHELLE	ABRAZADERA
	21	F000P01472	2	ANELLO OR	O-RING	JOINT TORIQUE	O-RING	JUNTA TORICA
	22	8H0099475	1	FASCETTA	CLAMP	COLLIER	SHELLE	ABRAZADERA

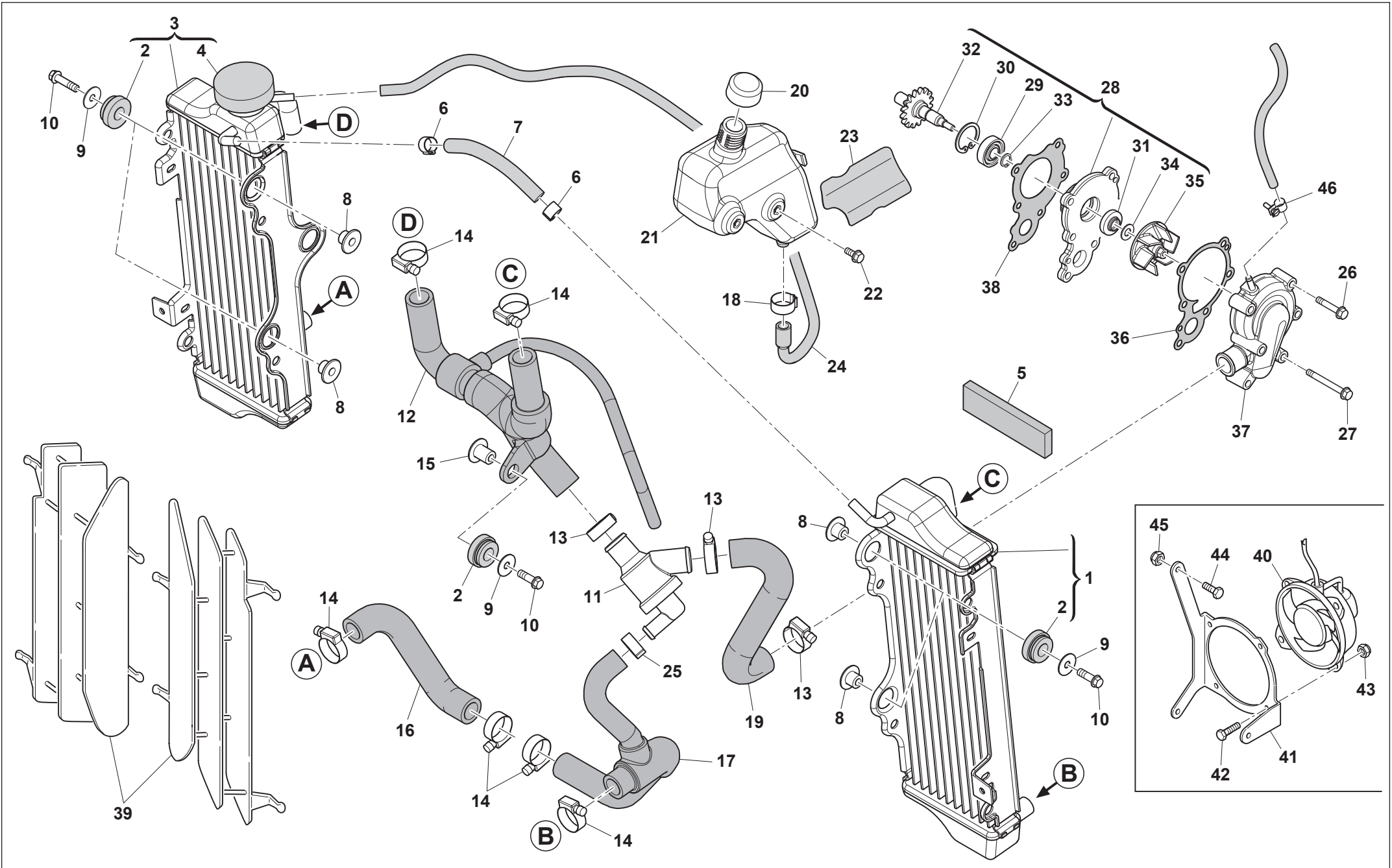



RS 125R/2017
SM 125R/2017

IMPIANTO RAFFREDDAMENTO OLIO - OIL COOLING SYSTEM
INSTALLATION RAFROIDISSEMENT HUILE - ÖL SCHMIERUNGSSYSTEM
EQUIPO DE ENFRIAMIENTO ACEITE

TAVOLA
DRAWING
TABLE
BILD
TABLA

16

Note Notes Notes Marke Notas	Pos. No. N. Index Pos.	N. Cod. Code No. Nr. Code Code Nr N. Cod.	Q.tà Q.ty Q.te M.ge C.ad	DENOMINAZIONE	NAME	DESIGNATION	BESHREIBUNG	DENOMINACION
	1	F000P00022	1	RADIATORE SINISTRO	L.H. RADIATOR	RADIATEUR GAUCHE	KÜHLER LINKS	RADIADOR IZQUIERDO
	2	F000P00025	6	GOMMINO	RUBBER RING	JOINT EN CAOUTCHOUC	GUMMISCHEIBE	GOMA
	3	F000P00023	1	RADIATORE DESTRO	RIGHT RADIATOR	RADIATEUR DROITE	KÜHLER RECHTS	RADIADOR DERECHO
	4	F000P00717	1	TAPPO	PLUG	BOUCHON	STOPFEN	TAPON
	5	800037140	1	ANTIVIBRANTE ADESIVO	SILENT-BLOCK STICKER	ADHÉSIF ANTIVIBRATION	AUFKLEBER SCHWINGUNGSDAMFER	ANTIVIBRADOR ADHESIVO
	6	8000H1981	2	FASCETTA CLIC 66-130	CLIC 66-130 CLAMP	COLLIER CLIC 66-130	SHELLE CLIC 66-130	ABRAZADERA CLIC 66-130
	7	8000H1298	1	TUBO RACCORDO RADIATORI L= 140mm	UNION-RADIATOR PIPE L= 140mm	TUYAU RACCORD RADIATEURS L= 140mm	ROHR ANSCHLUSS KÜHLER L= 140mm	TUBO RACOR RADIADORES L= 140mm
	8	800059802	5	BUSSOLA FISSAGGIO RADIATORE	RADIATOR BUSHING CLIP	DOUILLE FIXATION RADIATEURS	BUCHSE BEFESTIGUNG KUEHLERSCHUTZ	CASQUILLO FIJACIÓN RADIADORES
	9	Z00059801	6	ROSETTA	WASHER	RONDELLE	UNTERLEGSCHHEIBE	ARANDELA
	10	Z00062729	6	VITE TEF M6x25	FLANGED EXAGON HEAD SCREW M6x25	BOULON DE BRIDE M6x25	FLANSCHENSCHRAUBE M6x25	TORNILLO DE REBORDE M6x25
	11	8B0075984	1	TERMOSTATO	THERMOSTAT	THERMOSTAT	THERMOSTAT	TERMOSTATO
	12	F000P01339	1	TUBO MANDATA RADIATORI	RADIATOR DELIVERY PIPE	TUYAU DE REFOULEMENT RADIATEURS	KÜHLER VORLAUFROHR	TUBO ALIMENTACIÓN RADIADORES
	13	8B0099475	4	FASCETTA HOP 8-16/27	HOP 8-16/27 CLAMP	COLLIER HOP 8-16/27	SHELLE HOP 8-16/27	ABRAZADERA HOP 8-16/27
	14	8A0099475	6	FASCETTA HOP 8-10/22	HOP 8-10/22 CLAMP	COLLIER HOP 8-10/22	SHELLE HOP 8-10/22	ABRAZADERA HOP 8-10/22
	15	8E0059802	1	BUSSOLA	BUSHING	DOUILLE	BUCHSE	CASQUILLO
	16	F000P01340	1	TUBO RADIATORE DX	RH RADIATOR PIPE	TUYAU RADIATEUR D	ROHR KÜHLER RE	TUBO RADIADOR DCH.
	17	F000P01341	1	TUBO RADIATORE SX	LH RADIATOR PIPE	TUYAU RADIATEUR G	ROHR KÜHLER LI	TUBO RADIADOR IZQ.
	18	8A0092249	1	FASCETTA CLIC 96-175	CLIC 96-175 CLAMP	COLLIER CLIC 96-175	SHELLE CLIC 96-175	ABRAZADERA CLIC 96-175
	19	F000P01342	1	TUBO TERMOSTATO	THERMOSTAT PIPE	TUYAU THERMOSTAT	ROHR THERMOSTAT	TUBO TERMOSTATO
	20	800040427	1	TAPPO	PLUG	BOUCHON	STOPFEN	TAPON
	21	F000P01473	1	SERBATOIO ESPANSIONE	EXPANSION TANK	RÉSERVOIR D'EXPANSION	AUSDEHNUNGSGEFÄß	DEPÓSITO EXPANSIÓN
	22	ZE0067997	2	VITE TEF M5x10	FLANGED EXAGON HEAD SCREW M5x10	BOULON DE BRIDE M5x10	FLANSCHENSCHRAUBE M5x10	TORNILLO DE REBORDE M5x10
	23	F000P01785	1	TERMORIFLETTENTE ADESIVO	HEAT-REFLECTING STICKER	ADHÉSIF ISOLANT THERMIQUE	HITZEREFLEKTIERENDER SCHUTZ AUFKLEBER	TERMORREFLECTANTE ADHESIVO
	24	8000A1281	1	TUBO RADIATORE-SERBATOIO	OIL PIPE COOLER-TANK	TUBE RADIATEUR-RÉSERVOIR	ROHR ÖLKÜHLER-TANK	TUBO RADIADOR-DEPÓSITO
	25	8H0092249	1	FASCETTA	CLAMP	COLLIER	SHELLE	ABRAZADERA
	26	72012184	4	VITE TEF M5x38	FLANGED EXAGON HEAD SCREW M5x38	BOULON DE BRIDE M5x38	FLANSCHENSCHRAUBE M5x38	TORNILLO DE REBORDE M5x38
	27	72012185	2	VITE TEF M5x48	FLANGED EXAGON HEAD SCREW M5x48	BOULON DE BRIDE M5x48	FLANSCHENSCHRAUBE M5x48	TORNILLO DE REBORDE M5x48
	28	76220007	1	POMPA ACQUA COMPLETA	COMPLETE WATER PUMP	POMPE À EAU COMPLÈTE	WASSERPUMPE KOMPLETT	BOMBA AGUA COMPLETA
	29	17230008	1	CUSCINETTO 6000 26x10x8	BEARING 6000 26x10x8	ROULEMENT 6000 26x10x8	LAGER 6000 26x10x8	COJINETE 6000 26x10x8
	30	72080136	1	ANELLO DI FERMO INTERNO	INNER RETAINING RING	BAGUE D'ARRET	SICHERUNGSRING	ANILLO DE RETENCION
	31	17240008	1	ANELLO CORCOS 22x9x8,6	CORCOS 22x9x8,6 RING	BAGUE CORCOS 22x9x8,6	RING CORCOS 22x9x8,6	ANILLO CORCOS 22x9x8,6
	32	17220006	1	ALBERO POMPA ACQUA	WATER PUMP SHAFT	ARBRE POMPE A EAU	WELLE WASSERPUMPE	EJE BOMBA AGUA
	33	72080135	1	ANELLO DI FERMO	RETAINING RING	BAGUE D'ARRET	SICHERUNGSRING	ANILLO DE RETENCION

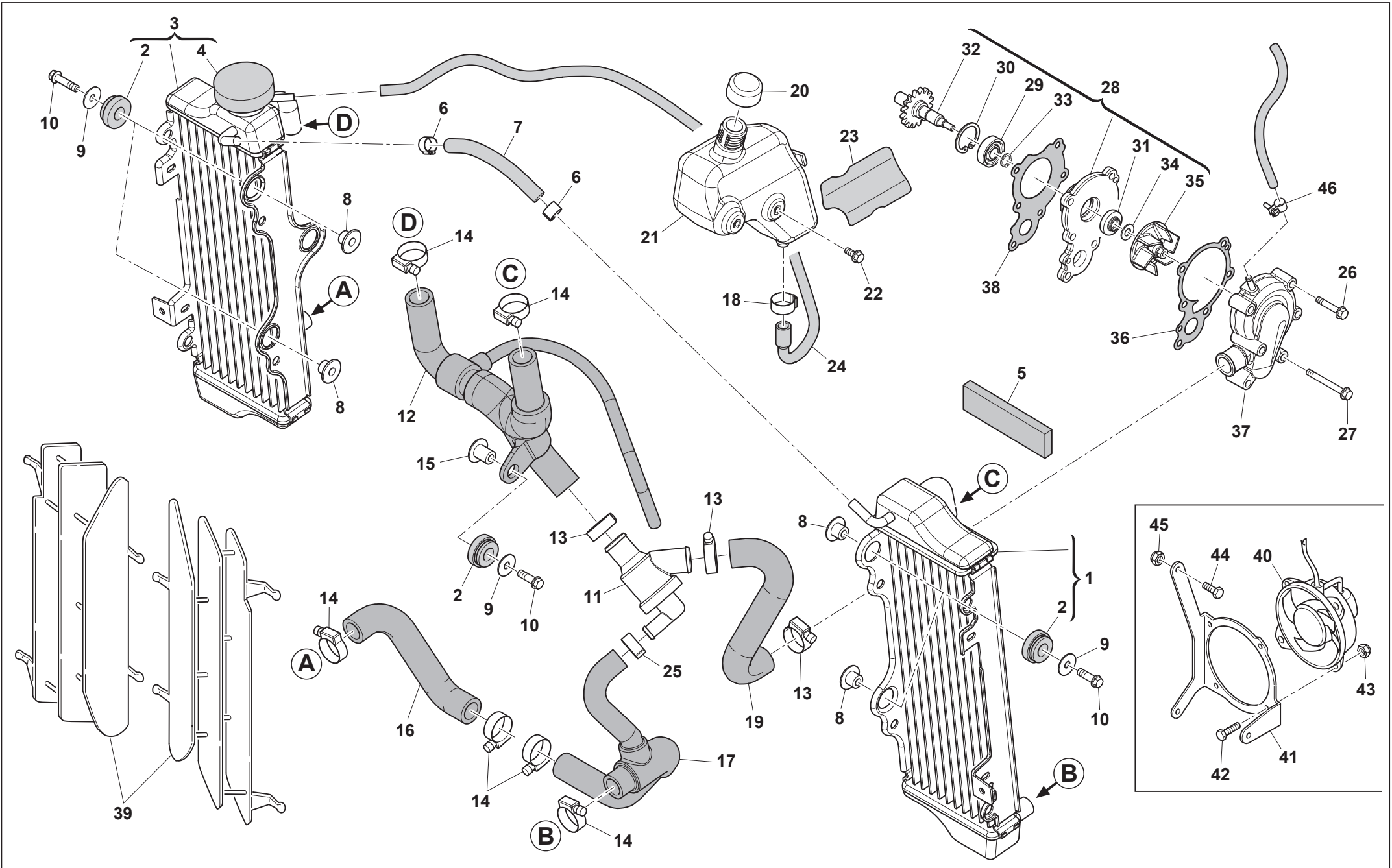



RS 125R/2017
SM 125R/2017

IMPIANTO RAFFREDDAMENTO OLIO - OIL COOLING SYSTEM
INSTALLATION RAFROIDISSEMENT HUILE - ÖL SCHMIERUNGSSYSTEM
EQUIPO DE ENFRIAMIENTO ACEITE

TAVOLA
DRAWING
TABLE
BILD
TABLA

16

Note Notes Notes Marke Notas	Pos. No. N. Index Pos.	N. Cod. Code No. Nr. Code Code Nr N. Cod.	Q.tà Q.ty Q.te M.ge C.ad	DENOMINAZIONE	NAME	DESIGNATION	BESHREIBUNG	DENOMINACION
	34	17030009	1	ROSETTA	WASHER	RONDELLE	UNTERLEGSSCHEIBE	ARANDELA
	35	17230006	1	GIRANTE POMPA ACQUA	WATER PUMP IMPELLER	ROTOR POMPE À EAU	WASSERPUMPE LAUFRAD	BOMBA AGUA RODETE
	36	72130625	1	GUARNIZIONE COPERCHIO POMPA	PUMP COVER GASKET	JOINT COUVERCLE POMPE	DICHTUNG DECKEL PUMPE	JUNTA TAPA BOMBA
	37	14140035	1	COPERCHIO POMPA ACQUA	WATER PUMP COVER	COUVERCLE POMPE À EAU	DECKEL WASSERPUMPE	TAPA BOMBA AGUA
	38	72130621	1	GUARNIZIONE BASE POMPA ACQUA	BASE WATER PUMP GASKET	JOINT BASE POMPE À EAU	DICHTUNG BODEN WASSERPUMPE	JUNTA BASE BOMBA AGUA
	39	80A0A0872	2	GRIGLIA RADIATORE	RADIATOR GRID	GRILLE RADIATEUR	GITTER KÜHLER	REJILLA RADIADOR
	40	8000A7715	1	ELETTOVENTOLA	ELECTRIC FAN	ELECTRO-VENTILATEUR	KÜHLGEBLÄSE	ELECTROVENTILADOR
	41	F000P00685	1	SUPPORTO ELETTOVENTOLA	ELECTRIC FAN SUPPORT	SUPPORT ELECTRO-VENTILATEUR	HALTERUNG KÜHLGEBLÄSE	SOPORTE ELECTROVENTILADOR
	42	60ND01030	4	VITE TE M4x25	HEXAGON SOCKET-HEAD BOLT M4x25	VIS M4x25	SCHRAUBE M4x25	TORNILLO M4x25
	43	Z00040717	4	DADO AUTOBLOCCANTE M4	SELF-LOCKING NUT M4	ECROU AUTOBLOQUANT M4	SELBSTSICHERNDE MUTTER M4	TUERCA AUTOBLOCANTE M4
	44	Z00062727	2	VITE TEF M6x16	FLANGED EXAGON HEAD SCREW M6x16	BOULON DE BRIDE M6x16	FLANSCHENSCHRAUBE M6x16	TORNILLO DE REBORDE M6x16
	45	Z00044240	2	DADO AUTOBLOCCANTE M6	SELF-LOCKING NUT M6	ECROU AUTOBLOQUANT M6	SELBSTSICHERNDE MUTTER M6	TUERCA AUTOBLOCANTE M6
	46	8B0091687	1	FASCETTA STRINGITUBO D13	D13 METALLIC CLIP	COLLIERT D13	SCHELLE D13	ABRAZADERA D13

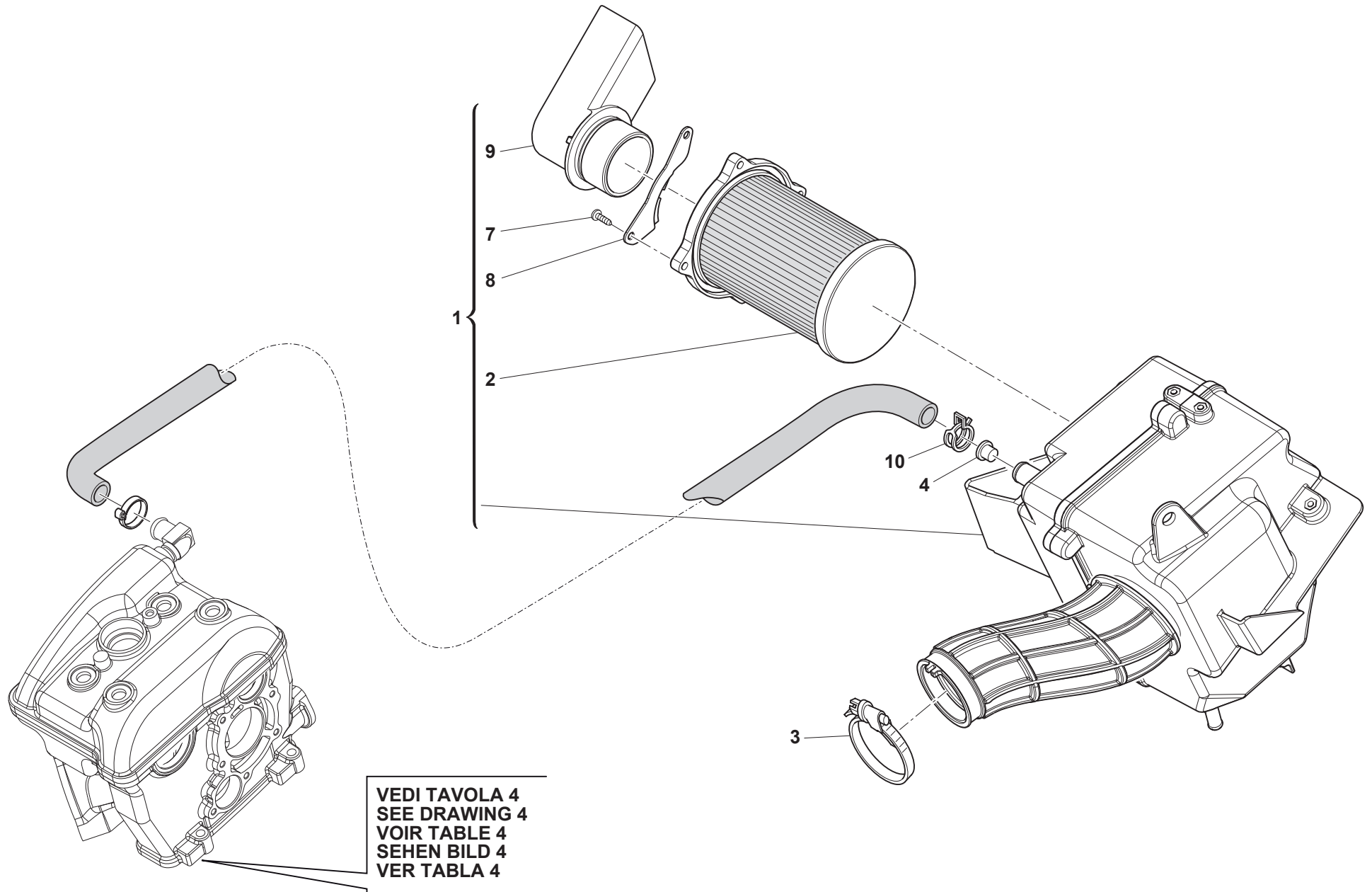

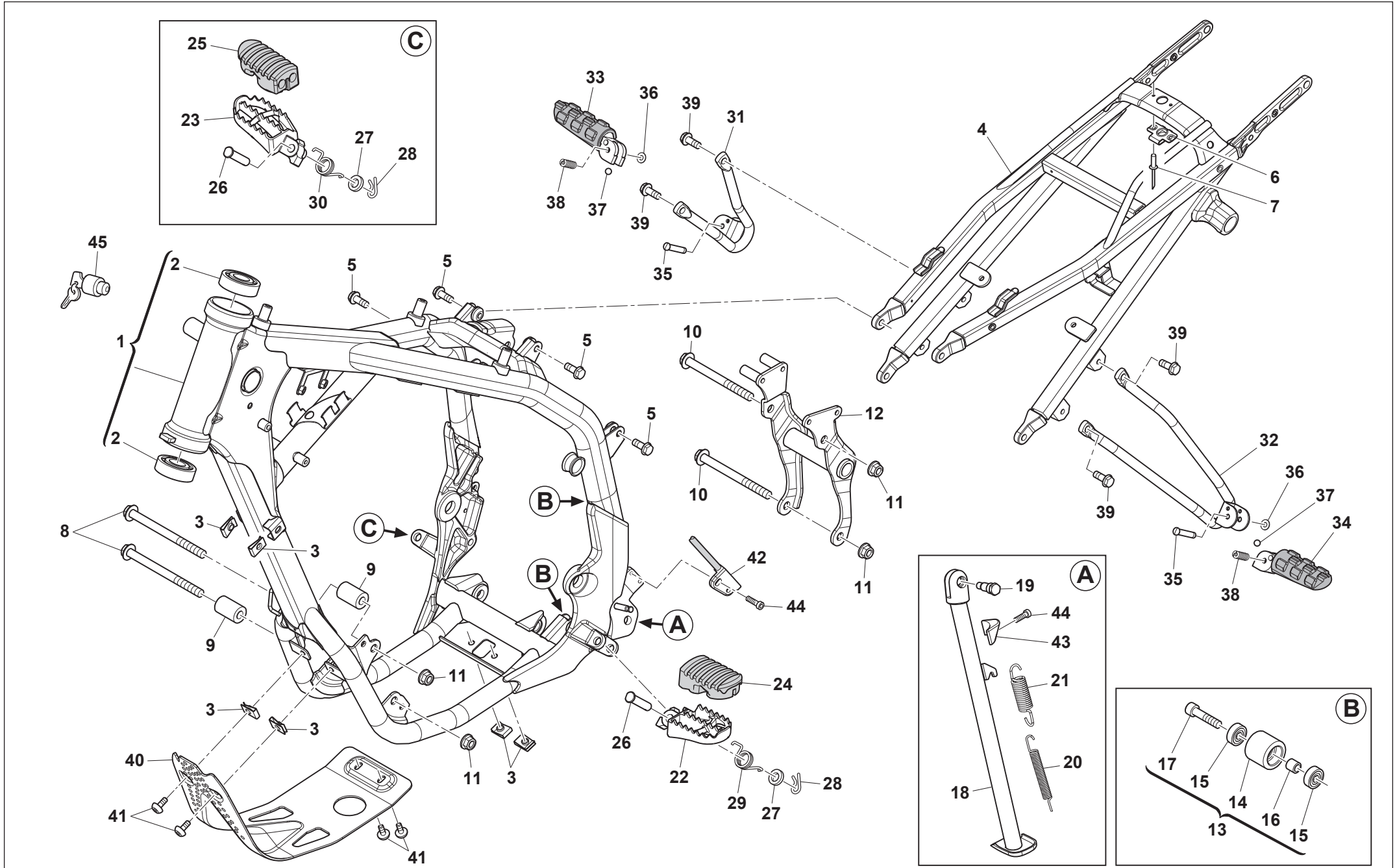



RS 125R/2017
SM 125R/2017

TELAIO, PEDANE - FRAME, FOOT RESTS
CADRE, REPOSE PIEDS - RAHMEN, FUSSBRETT
BASTIDOR, REPOSAPIES

TAVOLA
DRAWING
TABLE
BILD
TABLA

18

Note Notes Notes Marke Notas	Pos. No. N. Index Pos.	N. Cod. Code No. Nr. Code Code Nr N. Cod.	Q.tà Q.ty Q.te M.ge C.ad	DENOMINAZIONE	NAME	DESIGNATION	BESHREIBUNG	DENOMINACION
	1	F000A01275	1	TELAIO CON CUSCINETTI	FRAME WITH BEARINGS	CHÂSSIS AVEC ROULEMENTS	RAHMEN MIT LAGERN	CHASIS CON COJINETES
	2	F000P01572	2	CUSCINETTO A RULLI CONICI	TAPERED ROLLER BEARING	ROULEMENT À ROULEAUX CONIQUES	KEGELROLLENLAGER	COJINETE DE RODILLOS CÓNICOS
	3	U00046893	6	DADO A GRAFFETTA M6	CLIP NUT M6	ECROU À AGRAFE M6	SICHERUNGSMUTTER M6	TUERCA DE CLIP M6
	4	F000A01284	1	TELAIO POSTERIORE	REAR CHASSIS	CHÂSSIS ARRIÈRE	HINTERER RAHMEN	CHASIS TRASERO
	5	Z00069056	4	VITE TEF M8x20	FLANGED EXAGON HEAD SCREW M8x20	BOULON DE BRIDE M8x20	FLANSCHENSCHRAUBE M8x20	TORNILLO DE REBORDE M8x20
	6	800069150	1	PIASTRA D'ATTACCO SELLA	SADDLE ATTACHMENT PLATE	PLAQUE D'ATTACHE SELLE	ANSCHLUSSPLATTE SITZBANK	PLACA DE FIJACIÓN ASIENTO
	7	800033373	2	RIVETTO	RIVET	RIVET	NIET	REMACHE
	8	8R0069138	2	VITE M10x125	BOLT M10x125	VIS M10x125	SCHRAUBE M10x125	TORNILLO M10x125
	9	F000P01286	2	DISTANZIALE	SPACER	ENTRETOISE	ABSTANDHALTER	DISTANCIADOR
	10	8U0069138	2	VITE M10x110	BOLT M10x110	VIS M10x110	SCHRAUBE M10x110	TORNILLO M10x110
	11	Z00042022	4	DADO FRENATO M10x1,5	M10x1,5 SELF-LOCKING NUT	ECROU AUTOBLOQUANT M10x1,5	SELBSTSICHERNDE MUTTER M10x1,5	TUERCA AUTOBLOCANTE M10x1,5
	12	F000P01348	1	PIASTRA D'ATTACCO POSTERIORE MOTORE	ENGINE ATTACHMENT REAR PLATE	PLAQUE D'ATTACHE ARRIÈRE MOTEUR	ANSCHLUSSPLATTE HINTEN MOTOR	PLACA DE FIJACIÓN TRASERO MOTOR
	13	8C0059432	2	RULLO CATENA COMPLETO	CHAIN ROLLER ASSY	GALET DE CHÂÎNE COMPLET	KETTENROLLE KOMPLETT	RODILLO CADENA COMPLETO
	14	8AA059433	2	RULLO CATENA	CHAIN ROLLER	GALET DE CHÂÎNE	KETTENROLLE	RODILLO CADENA
	15	800063312	4	CUSCINETTO A SFERE 22x8x7	22x8x7 BALL BEARING	ROULEMENT À BILLES 22x8x7	KUGELLAGER 22x8x7	COJINETE DE BOLAS 22x8x7
	16	8A0059434	2	DISTANZIALE	SPACER	ENTRETOISE	ABSTANDHALTER	DISTANCIADOR
	17	60ND02559	2	VITE M8x40	BOLT M8x40	VIS M8x40	SCHRAUBE M8x40	TORNILLO M8x40
SM 125R	18	F000P01287	1	CAVALLETTO LATERALE	LATERAL STAND	BÉQUILLE	STÄNDER	CABALLETE LATERAL
RS 125R	18	FA00P01287	1	CAVALLETTO LATERALE	LATERAL STAND	BÉQUILLE	STÄNDER	CABALLETE LATERAL
	19	F000P01802	1	VITE ROTAZIONE CAVALLETTO LATERALE	SIDE STAND SCREW	VIS BÉQUILLE	SCHRAUBE STÄNDER	TORNILLO CABALLETE
	20	8000A0268	1	MOLLA INTERNA	INTERNAL SPRING	RESSORT INTERIEUR	INTERNE FEDER	MUELLE INTERNO
	21	8000A0269	1	MOLLA ESTERNA	EXTERNAL SPRING	RESSORT EXTERIEUR	EXTERNE FEDER	MUELLE EXTERNO
	22	F000P01246	1	PEDANA SINISTRA	L.H. FOOTREST	REPOSE-PIEDS GAUCHE	FU&RASTE LINKS	ESTRIBO IZQUIERDA
	23	F000P01247	1	PEDANA DESTRA	R.H. FOOTREST	REPOSE-PIEDS DROITE	FU&RASTE RECHTS	ESTRIBO DERECHA
	24	F000P00138	1	GOMMINO PEDANA SINISTRA	LEFT FOOTREST RUBBER	CAOUTCHOUC	GUMMI	GOMA
	25	F000P00139	1	GOMMINO PEDANA DESTRA	RIGHT FOOTREST RUBBER	CAOUTCHOUC	GUMMI	GOMA
	26	Y00073140	2	PERNO	PIN	AXE	BOLZEN	EJE
	27	ZA0001815	2	ROSETTA [D16-D10,5-SP1]	[D16-D10,5-SP1] WASHER	RONDELLE [D16-D10,5-SP1]	UNTERLEGSSCHEIBE [D16-D10,5-SP1]	ARANDELA [D16-D10,5-SP1]
	28	64ND20068	2	COPIGLIA L=18 mm	L=18 mm SPLIT PIN	GOUPILLE L=18 mm	SPLINT L=18 mm	PASADOR L=18 mm
	29	800096907	1	MOLLA PEDANA SINISTRA	SPRING	RESSORT	FEDER	MUELLE
	30	800096908	1	MOLLA PEDANA DESTRA	SPRING	RESSORT	FEDER	MUELLE
	31	F000P01345	1	SUPPORTO POGGIAPIEDI PASSEGGERO DX	RH PASSENGER FOOTREST	REPOSE-PIEDS PASSAGER D	BEIFÄHRERFU&RASTE RE	REPOSAPIÉS ACOMPAÑANTE DCH.
	32	F000P01346	1	SUPPORTO POGGIAPIEDI PASSEGGERO SX	LH PASSENGER FOOTREST	REPOSE-PIEDS PASSAGER G	BEIFÄHRERFU&RASTE LI	REPOSAPIÉS ACOMPAÑANTE IZQ.

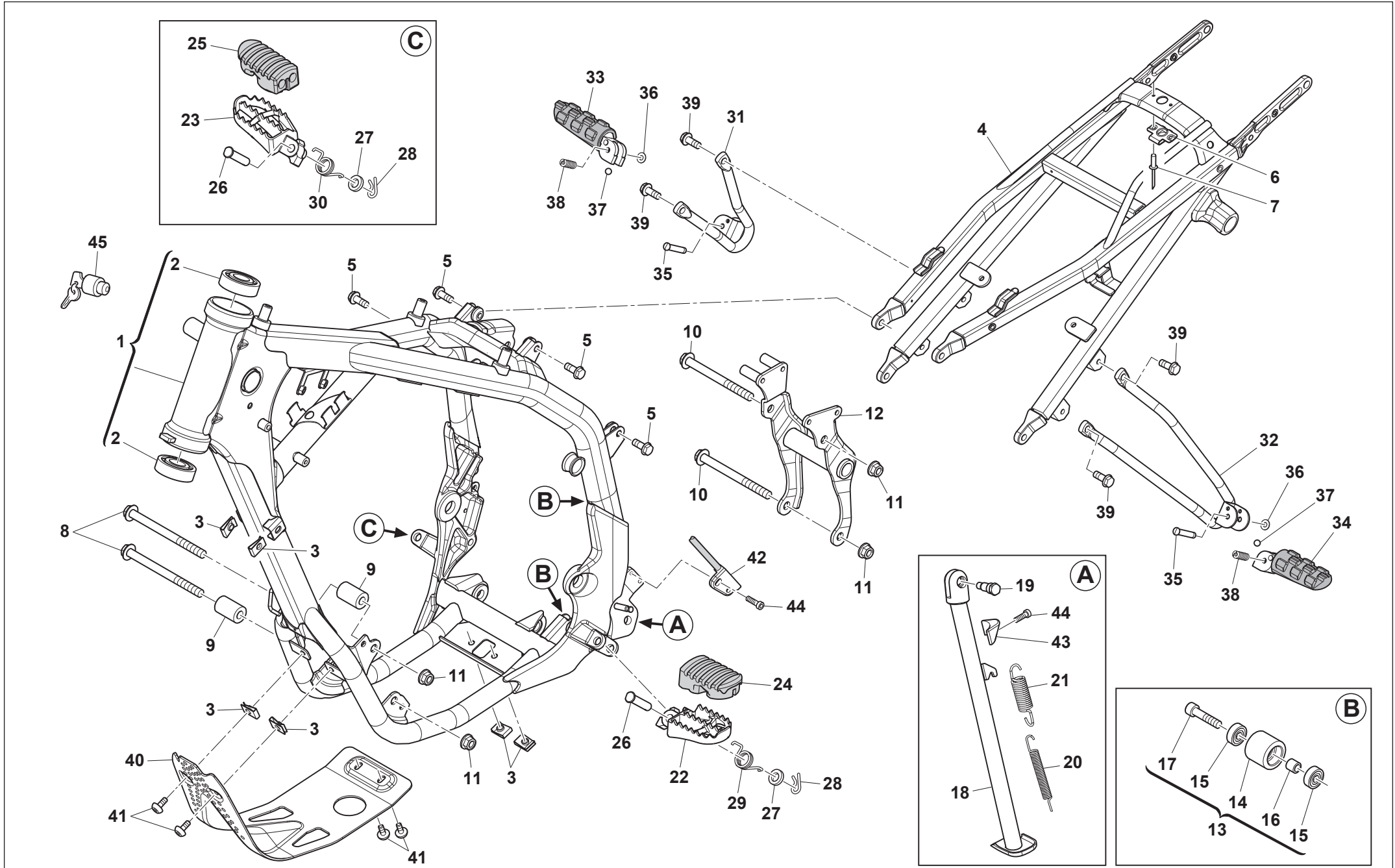

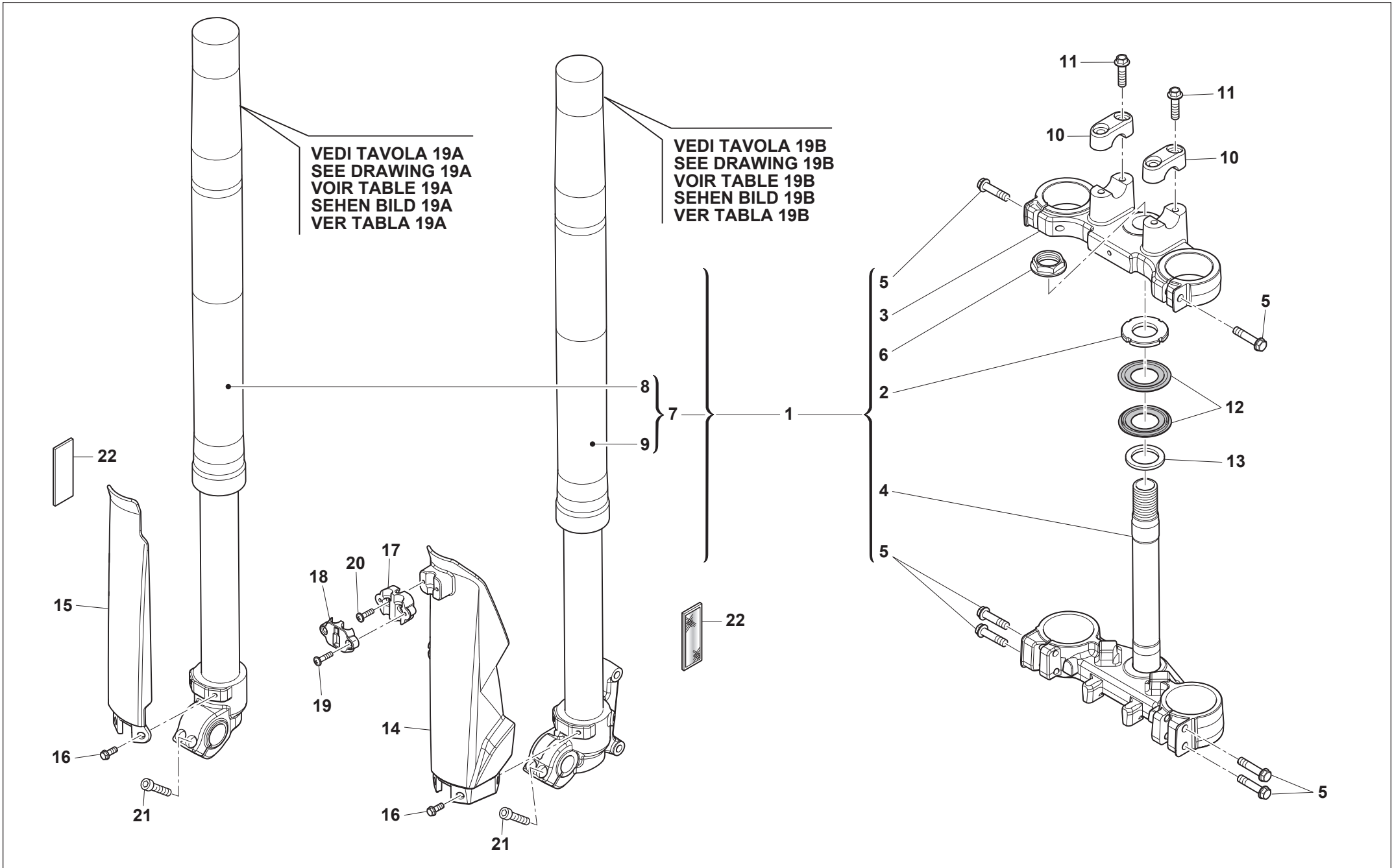



RS 125R/2017
SM 125R/2017

SOSPENSIONE ANTERIORE - FRONT FORK ASSEMBLY
SUSPENSION AVANT - VORDERTELESKOPGABEL
SUSPENSION DELANTERA

TAVOLA
DRAWING
TABLE
BILD
TABLA

19

Note Notes Notes Marke Notas	Pos. No. Index Pos.	N. Cod. Code No. Nr. Code Code Nr N. Cod.	Q.tà Q.ty Q.te M.ge C.ad	DENOMINAZIONE	NAME	DESIGNATION	BESHREIBUNG	DENOMINACION
	1	F000A01299	1	ASS. SOSPENSIONE ANTERIORE	FRONT SUSPENSION ASSY	SUSPENSION AVANT	RADAUFHAENGUNG VORDER	SUSPENSION DELANTERA
	2	8A0087717	1	GHIERA PER PERNO DI STERZO	RING NUT	BAGUE	GEWINDERING	TUERCA ANULAR
	3	F000P01300	1	TESTA DI STERZO	STEERING HEAD	TETE DE DIRECTION	LENKKOPF	CABEZAL DE DIRECCIÓN
	4	F000A01301	1	BASE DI STERZO CON PERNO	BOTTOM YOKE WITH PIN	BASE DE DIRECTION AVEC AXE	LENKLAGER MIT BOLZEN	BASE DE DIRECCIÓN CON EJE
	5	8E00B1959	6	VITE TEF M8x40	FLANGED EXAGON HEAD SCREW M8x40	BOULON DE BRIDE M8x40	FLANSCHENSCHRAUBE M8x40	TORNILLO DE REBORDE M8x40
	6	8A0069315	1	DADO M26	NUT M26	ECROU M26	MUTTER M26	TUERCA M26
	7	F000A01303	1	ASSIEME GAMBE FORCELLA	FORK LEGS ASSY	ENSEMBLE FOURCHE	GABELGRUPPE	GRUPO HORQUILLA
	8	F000P01304	1	GAMBA DESTRA COMPLETA	COMPLETE R.H. SHOCK ABSORBER	BRANCHE DROITE COMPLÈTE	FEDERBEIN RECHTS KOMPLETT	PATA DER. COMPLETA
	9	F000P01305	1	GAMBA SINISTRA COMPLETA	COMPLETE L.H. SHOCK ABSORBER	BRANCHE GAUCHE COMPLÈTE	FEDERBEIN LINKE KOMPLETT	PATA IZQ. COMPLETA
	10	F000P01591	2	MORSETTO SUPERIORE	UPPER CLAMP	ETRIER SUPÉRIEUR	KLEMME OBEN	BORNE SUPERIOR
	11	8A00B1959	4	VITE TEF M8x30	FLANGED EXAGON HEAD SCREW M8x30	BOULON DE BRIDE M8x30	FLANSCHENSCHRAUBE M8x30	TORNILLO DE REBORDE M8x30
	12	800087745	2	GUARNIZIONE DI TENUTA	GASKET	JOINT D'ÉTANCHÉITÉ	DICHTUNG	JUNTA DE ESTANQUEIDAD
	13	800087736	1	ROSETTA	WASHER	RONDELLE	UNTERLEGSSCHEIBE	ARANDELA
B	14	F000A01456	1	PROTEZIONE FORCELLA SX	L.H. LEG PROTECTION	PROTECTION TIGES GAUCHE	SCHUTZ SCHÄFTE LINKS	PROTECCIÓN VÁSTAGOS IZQ.
A	14	F000A01691	1	PROTEZIONE FORCELLA SX	L.H. LEG PROTECTION	PROTECTION TIGES GAUCHE	SCHUTZ SCHÄFTE LINKS	PROTECCIÓN VÁSTAGOS IZQ.
B	15	F000A01457	1	PROTEZIONE FORCELLA DX	R.H. LEG PROTECTION	PROTECTION TIGES DROIT	SCHUTZ SCHÄFTE RECHTS	PROTECCIÓN VÁSTAGOS DER.
A	15	F000A01692	1	PROTEZIONE FORCELLA DX	R.H. LEG PROTECTION	PROTECTION TIGES DROIT	SCHUTZ SCHÄFTE RECHTS	PROTECCIÓN VÁSTAGOS DER.
	16	8000A8423	6	VITE FLANGIATA M6x8	M6x8 FLANGED SCREW	VIS BRIDÉE M6x8	FLANSCHSCHRAUBE M6x8	TORNILLO CON BRIDA M6x8
B	17	FOA0P01312	1	CAVALLOTTO	CLAMP	BOULON	BÜGELSCHRAUBE	CABALLETE
A	17	FOB0P01312	1	CAVALLOTTO	CLAMP	BOULON	BÜGELSCHRAUBE	CABALLETE
B	18	FOA0P01455	1	COPERCHIO	COVER	COUVERCLE	DECKEL	TAPA
A	18	FOB0P01455	1	COPERCHIO	COVER	COUVERCLE	DECKEL	TAPA
	19	ZA0084658	2	VITE AUTOFILETTANTE	SCREW, TAPPING	VIS TARAUD	GEWINDESCHRAUBE	TORNILLO AUTOROSCANTE
	20	Z00084658	2	VITE AUTOFILETTANTE	SCREW, TAPPING	VIS TARAUD	GEWINDESCHRAUBE	TORNILLO AUTOROSCANTE
	21	F000P02052	4	VITE	BOLT	VIS	SCHRAUBE	TORNILLO
	22	800074842	2	CATADIOTTRO CON BASETTA	REFLECTOR WITH MOUNT	CATADIOPTRIC AVEC EMBASE	RÜCKSTRAHLER MIT SOCKEL	CATADIÓPTRICO CON APOYO DE BASE

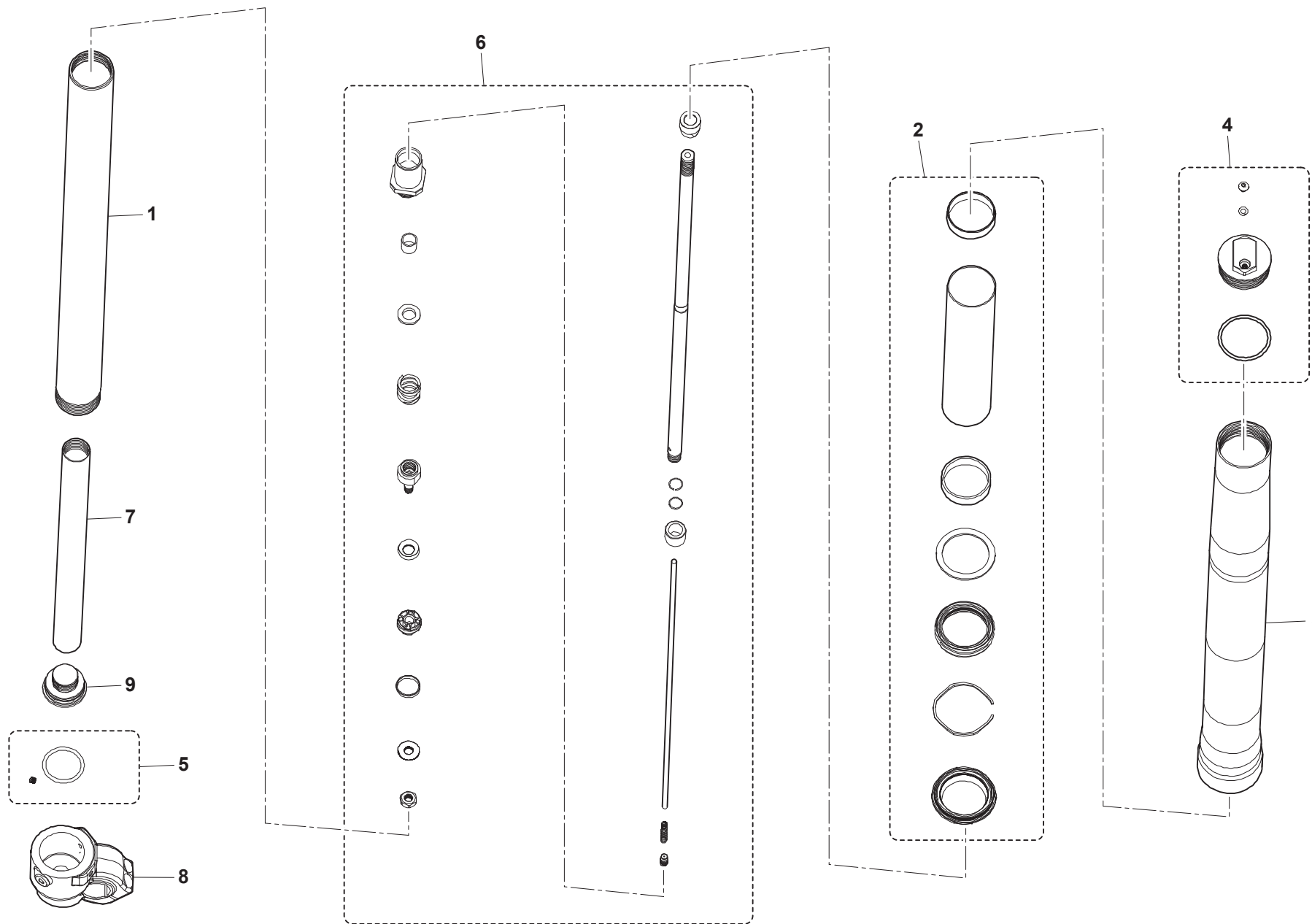

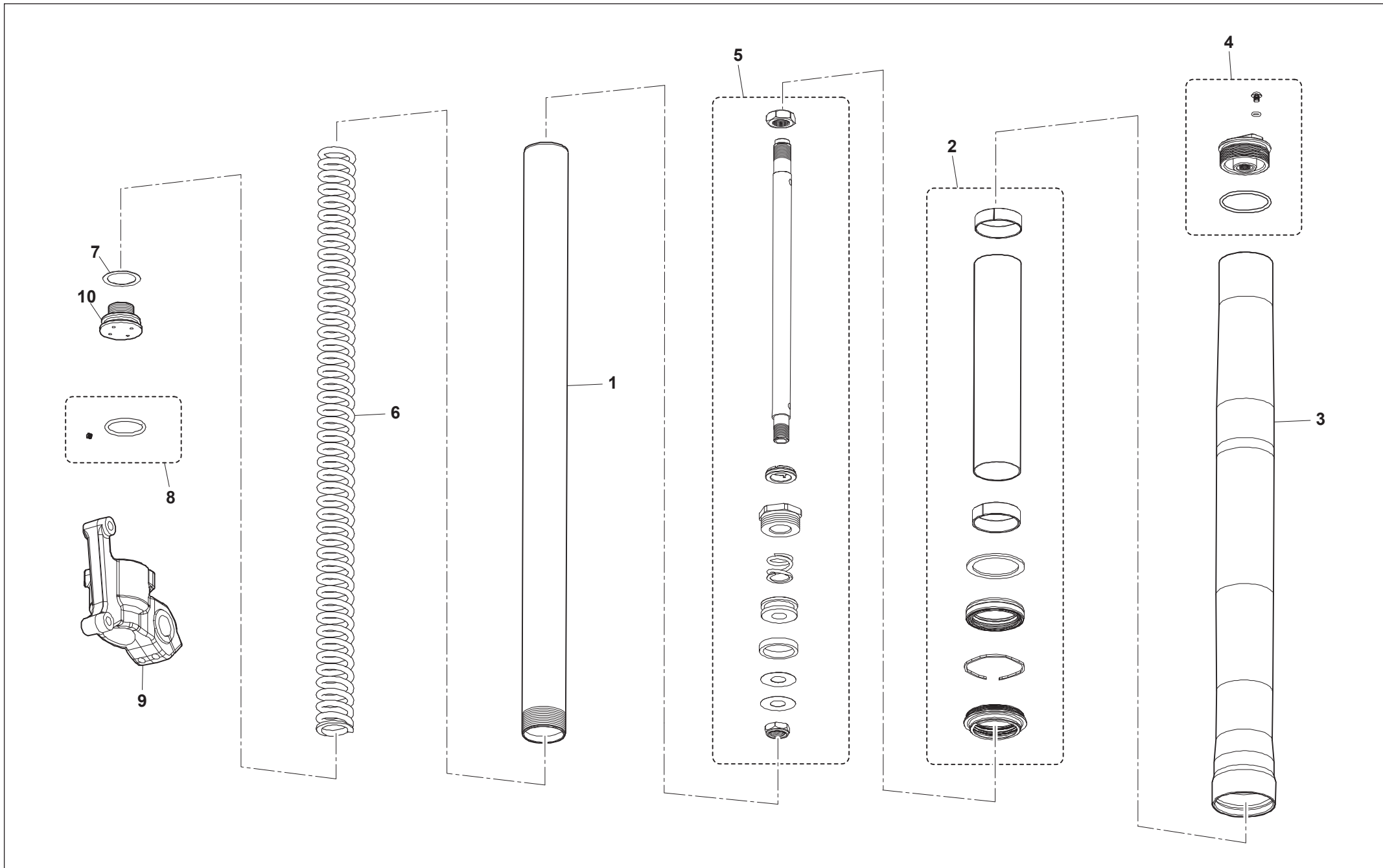

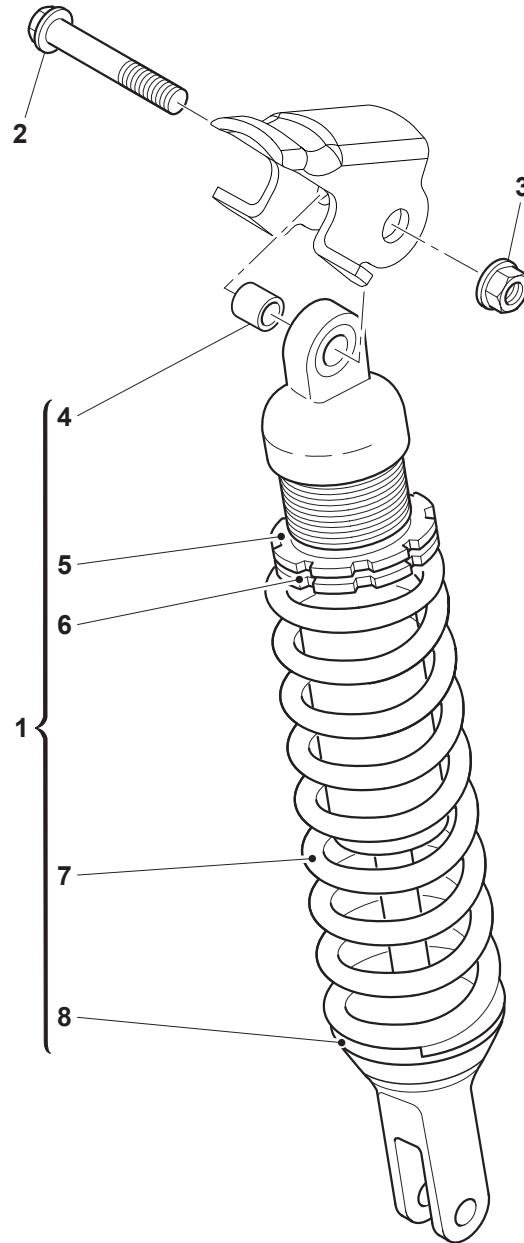

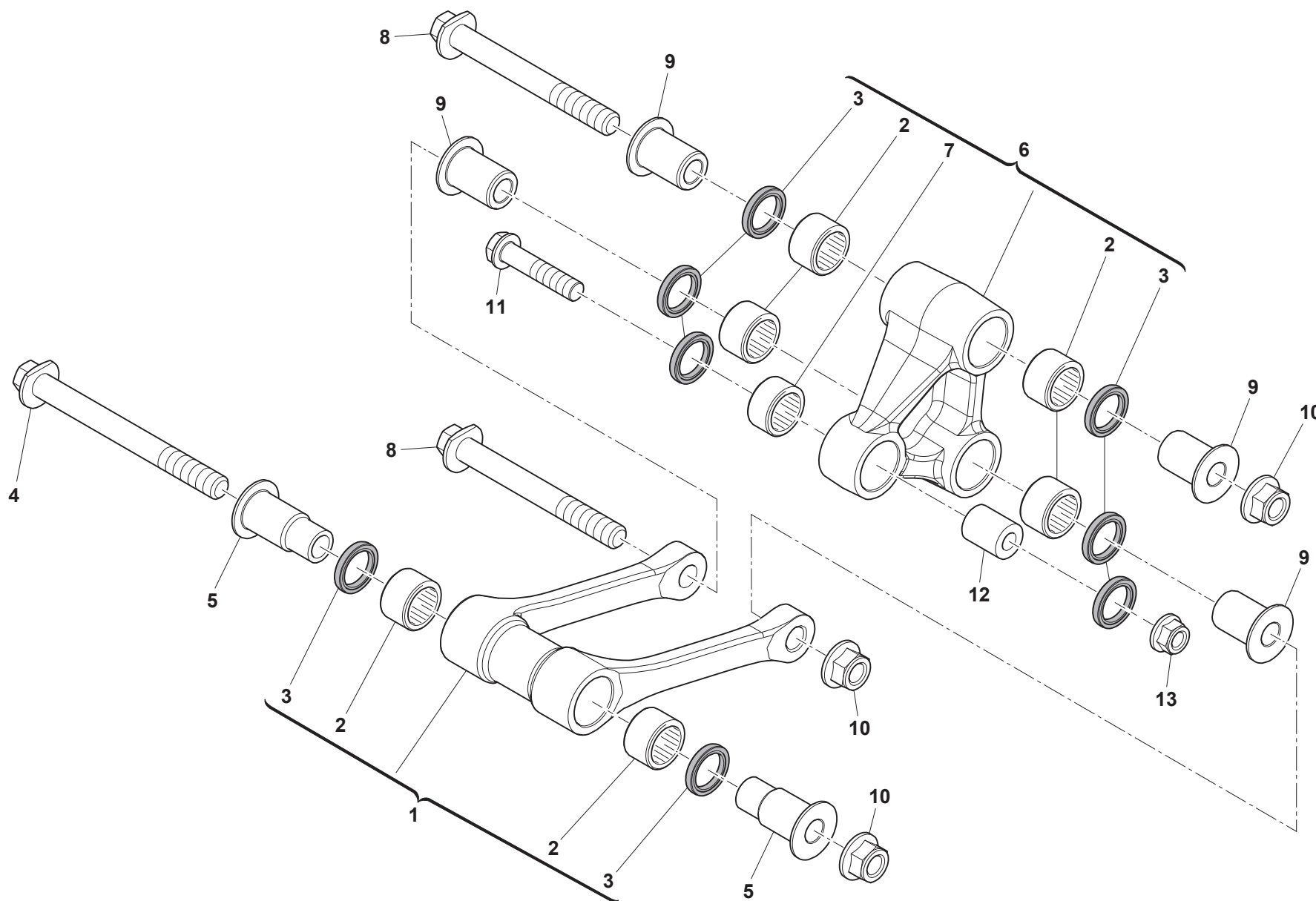

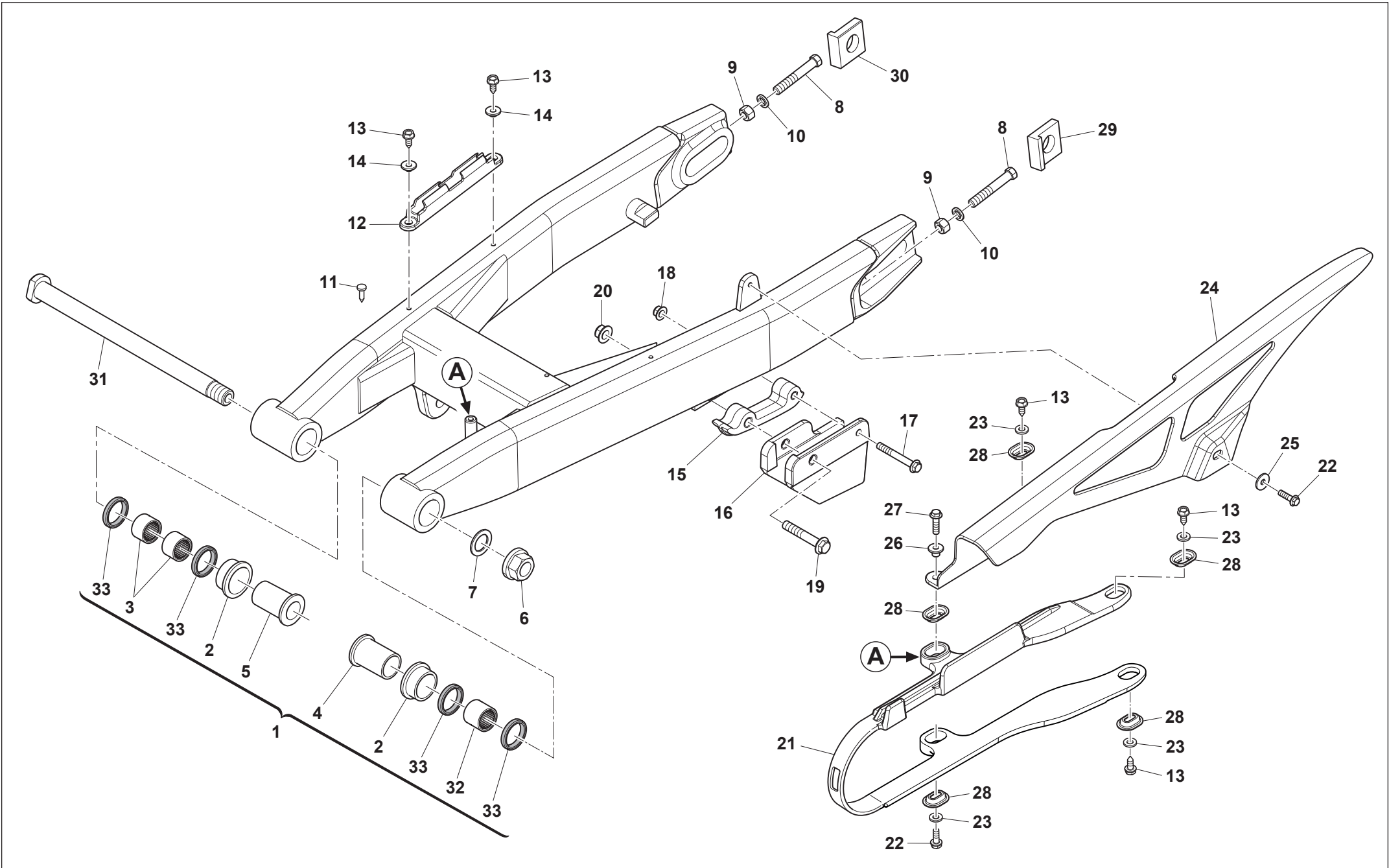



RS 125R/2017
SM 125R/2017

FORCELLONE POSTERIORE - REAR SWING ARM
FOURCHE ARRIERE - HINTERGABEL
HORQUILLA TRASERA

TAVOLA
DRAWING
TABLE
BILD
TABLA

22

Note Notes Marke Notas	Pos. No. Index Pos.	N. Cod. Code No. Nr. Code Code Nr N. Cod.	Q.tà Q.ty Q.te M.ge C.ad	DENOMINAZIONE	NAME	DESIGNATION	BESHREIBUNG	DENOMINACION
	1	F000A01306	1	FORCELLONE COMPLETO	COMPLETE SWINGING ARM	BRAS OSCILLANT COMPLET	SCHWINGE KOMPLETT	BASCULANTE COMPLETO
	2	F000P01308	2	BUSSOLA	BUSHING	DOUILLE	BUCHSE	CASQUILLO
	3	F000P01309	2	GABBIA A RULLINI	NEEDLE CAGE	CAGE À AIGUILLES	NADELKÄFIG	JAULA DE RODILLOS
	4	F000P01310	1	DISTANZIALE SINISTRO	LEFT SPACER	ENTRETOISE GAUCHE	ABSTANDHALTER LINKS	DISTANCIADOR IZQUIERDO
	5	F000P02067	1	DISTANZIALE DESTRO	RIGHT SPACER	ENTRETOISE DROIT	ABSTANDHALTER RECHTS	DISTANCIADOR DERECHO
	6	Z00071623	1	DADO FLANGIATO M16	FLANGED NUT M16	ECROU BRIDE M16	FLANSCHMUTTER M16	TUERCA CON BRIDA M16
	7	800032388	1	ROSETTA	WASHER	RONDELLE	UNTERLEGSCHIEBE	ARANDELA
	8	ZC0061121	2	VITE TE M8x1,25	HEXAGON SOCKET-HEAD BOLT M8x1,25	VIS M8x1,25	SCHRAUBE M8x1,25	TORNILLO M8x1,25
	9	Z00017810	2	DADO M8	NUT M8	ECROU M8	MUTTER M8	TUERCA M8
	10	Z00008536	2	ROSETTA	WASHER	RONDELLE	UNTERLEGSCHIEBE	ARANDELA
	11	800075160	2	RIVETTO	RIVET	RIVET	NIET	REMACHE
	12	8000B1166	1	PASSATUBO FRENO POSTERIORE	REAR BRAKE HOSE RING	PASSE-TUBE DE FREIN ARRIERE	LEITUNGSDURCHFÜHRUNG HINTERRADBREMSE	PASATUBO FRENO TRASERO
	13	Z00020536	5	VITE AUTOFILETTANTE	SCREW, TAPPING	VIS TARAUD	GEWINDESCHRAUBE	TORNILLO AUTOROSCANTE
	14	800069282	2	BUSSOLA Ø14xØ7xØ5,25	BUSHING Ø14xØ7xØ5,25	DOUILLE Ø14xØ7xØ5,25	BUCHSE Ø14xØ7xØ5,25	CASQUILLO Ø14xØ7xØ5,25
	15	F000P01358	1	GUIDACATENA INTERNO	INNER DRIVE CHAIN	GUIDE DE CHAÎNE INTÉRIEUR	KETTENFÜHRUNG INNEN	GUÍA CADENA INTERNO
	16	F000P00595	1	GUIDACATENA ESTERNO	EXTERNAL DRIVE CHAIN	GUIDE DE CHAÎNE EXTERIEURE	KETTENFÜHRUNG EXTERNER	GUÍA CADENA EXTERNO
	17	Z00062731	1	VITE TEF M6x45	FLANGED EXAGON HEAD SCREW M6x45	BOULON DE BRIDE M6x45	SCHRAUBE M6x45	TORNILLO M6x45
	18	Z00044240	1	DADO M6x1	NUT M6x1	ECROU M6x1	MUTTER M6x1	TUERCA M6x1
	19	Z00062795	1	VITE TEF M8x50	FLANGED EXAGON HEAD SCREW M8x50	BOULON DE BRIDE M8x50	FLANSCHSCHRAUBE M8x50	TORNILLO DE REBORDE M8x50
	20	Y00043928	1	DADO M8x1,25	NUT M8x1,25	ECROU M8x1,25	MUTTER M8x1,25	TUERCA M8x1,25
	21	8000H1320	1	PATTINO CATENA	CHAIN SLIDER	PATIN CHAÎNE	KETTENSANNERAUFLAGE	PATÍN CADENA
	22	Z00067997	2	VITE TEF M5x12	FLANGED EXAGON HEAD SCREW M5x12	BOULON DE BRIDE M5x12	FLANSCHSCHRAUBE M5x12	TORNILLO DE REBORDE M5x12
	23	Z00036137	4	ROSETTA	WASHER	RONDELLE	UNTERLEGSCHIEBE	ARANDELA
	24	F000P01344	1	COPRICATENA	CHAIN GUARD	CARTER DE CHAÎNE	KETTENKASTEN	CUBRECADENA
	25	F000P01904	1	ROSETTA	WASHER	RONDELLE	UNTERLEGSCHIEBE	ARANDELA
	26	8A0069282	1	BUSSOLA Ø14xØ7xØ7,8	BUSHING Ø14xØ7xØ7,8	DOUILLE Ø14xØ7xØ7,8	BUCHSE Ø14xØ7xØ7,8	CASQUILLO Ø14xØ7xØ7,8
	27	ZC0067997	1	VITE TEF M5x20	FLANGED EXAGON HEAD SCREW M5x20	BOULON DE BRIDE M5x20	FLANSCHSCHRAUBE M5x20	TORNILLO DE REBORDE M5x20
	28	8000H3033	7	SCODELLINO	RETAINER	RONDELLE A RESSORT	FEDERTELLER	ASIENTO
	29	F000P01334	1	TENDICATENA SINISTRA	LEFT CHAIN TENSIONER	TENDEUR DE CHAÎNE GAUCHE	KETTENSANNER LINKS	SENSOR DE CADENA IZQUIERDO
	30	80096944	1	TENDICATENA DESTRA	RIGHT CHAIN TENSIONER	TENDEUR DE CHAÎNE DROIT	KETTENSANNER RECHTS	SENSOR DE CADENA DERECHO
	31	FA00P00173	1	PERNO FORCELLONE	SWINGING ARM PIN	AXE BRAS OSCILLANT	BOLZEN SCHWINGE	EJE BASCULANTE
	32	F000P03732	1	GABBIA A RULLINI	NEEDLE CAGE	CAGE À AIGUILLES	NADELKÄFIG	JAULA DE RODILLOS
	33	800038521	4	PARAPOLVERE	DUST SEAL	CACHE-POUSSIÈRES	STAUBSCHUTZ	GUARDAPOLVO

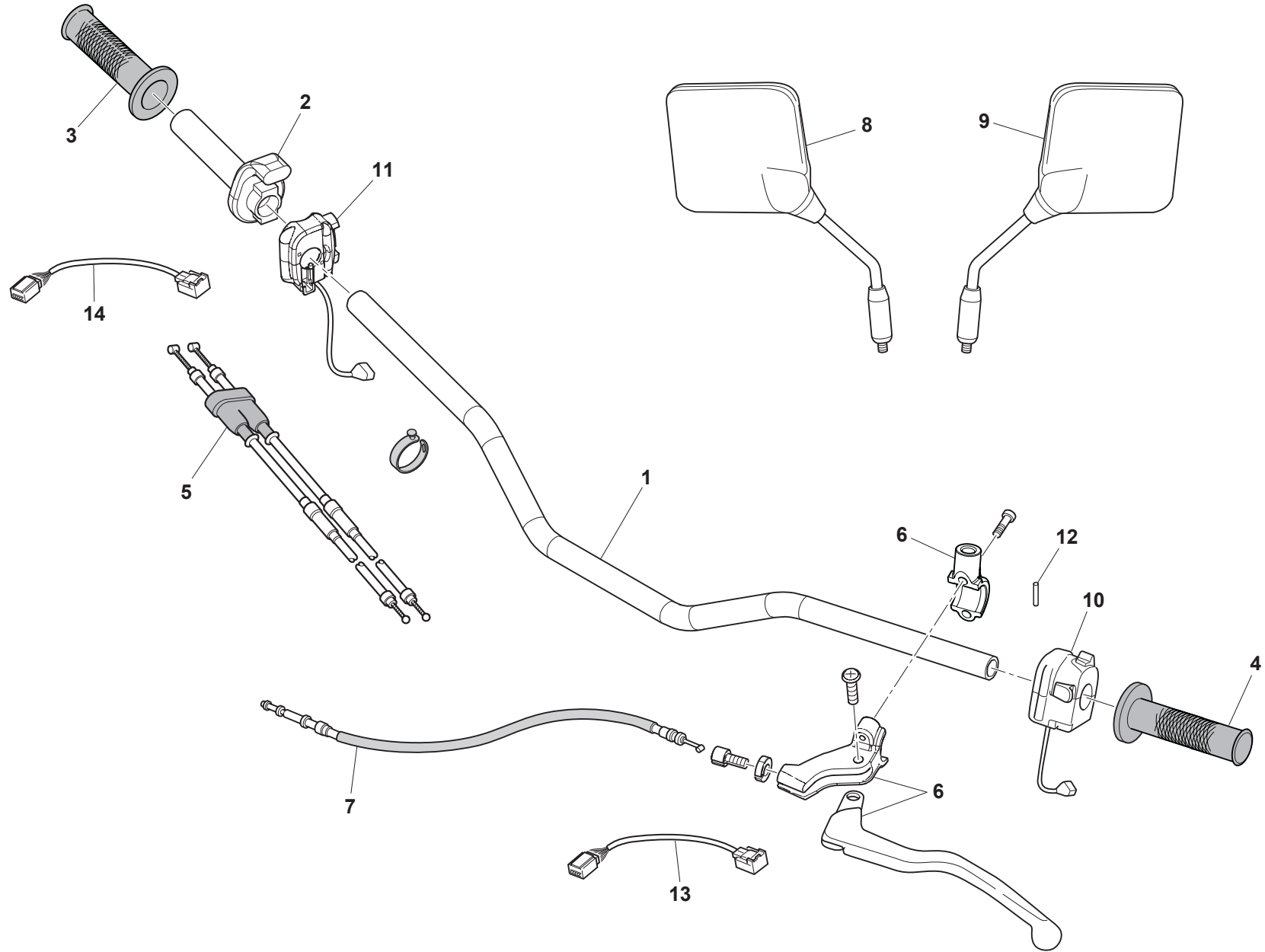



RS 125R/2017
SM 125R/2017

MANUBRIO E COMANDI - HANDLEBAR AND CONTROLS
GUIDON ET COMMANDES - LENKER UND STEUERORGANE
MANILLAR Y MANDOS

TAVOLA
DRAWING
TABLE
BILD
TABLA

23

Note Notes Marke Notas	Pos. No. Index Pos.	N. Cod. Code No. Nr. Code Code Nr N. Cod.	Q.tà Q.ty Q.te M.ge C.ad	DENOMINAZIONE	NAME	DESIGNATION	BESHREIBUNG	DENOMINACION
	1	F000P01288	1	MANUBRIO	HANDLEBAR	GUIDON	LENKER	MANILLAR
	2	800098209	1	COMANDO GAS COMPLETO	COMPLETE THROTTLE CONTROL	COMMANDE DES GAZ COMPLÈTE	GASZUG KOMPLETT	MANDO ACELERADOR COMPLETO
	3	800076688	1	MANOPOLA DESTRA	RH HANDGRIP	POIGNÉE DROITE	GRIFF RECHTS	PUÑO DERECHA
	4	800076687	1	MANOPOLA SINISTRA	L.H. HANDGRIP	POIGNÉE GAUCHE	GRIFF LINKS	PUÑO IZQUIERDA
	5	8000B1927	1	TRASMISSIONE COMANDO GAS	THROTTLE CONTROL DRIVE AND TRANSMISSION	TRANSMISSION COMMANDE DES GAZ	GASZUG	TRANSMISIÓN MANDO ACELERADOR
	6	F000P01292	1	ASSIEME COMANDO FRIZIONE	CLUTCH CONTROL ASSY	COMMANDE EMBRAYAGE COMPL.	ZUSAMMENBAU KUPPLUNGSZUG	CONJUNTO MANDO EMBRAGUE
	7	F000P01293	1	TRASM. COMANDO FRIZIONE	CLUTCH CONTROL DRIVE AND TRANSMISSION	TRANSM. COMMANDE EMBRAYAGE	KUPPLUNGSZUG	TRANSM. MANDO EMBRAGUE
	8	FA00P01471	1	SPECCHIETTO RETROV. DX	R.H. REAR-VIEW MIRROR	RÉTROVISEUR DROITE	RÜCKSPIEGEL RECHTS	ESPEJO RETROV. DER.
	9	F000P01471	1	SPECCHIETTO RETROV. SX	L.H. REAR-VIEW MIRROR	RÉTROVISEUR GAUCHE	RÜCKSPIEGEL LINKE	ESPEJO RETROV. IZQ.
	10	8000H1173	1	COMMUTATORE SINISTRO	LEFT HANDLE SWITCH	COMMUTATEUR GAUCHE	UMSCHALTER LINKS	CONMUTADOR IZQUIERDO
	11	8000H1174	1	COMMUTATORE DESTRO	RIGHT SWITCH	COMMUTATEUR DROITE	UMSCHALTER RECHTS	CONMUTADOR DERECHO
	12	8000A1074	1	PIOLO IN GOMMA	RUBBER PIN	PLOT EN CAOUTCHOU	GUMMIDÜBEL	CLAVIJA DE GOMA
	13	E000P01623	1	CABLAGGIO MICROINTERRUTTORE FRIZIONE	CLUTCH MICROSWITCH CABLE HARNESS	CÂBLAGE MICROINTERRUPTEUR EMBRAYAGE	VERKABELUNG KUPPLUNGS MIKROSCHALTER	CABLEADO MICROINTERRUPTOR EMBRAGUE
	14	E000P01624	1	CABLAGGIO MICROINTERRUTTORE FRENO	BRAKE MICROSWITCH CABLE HARNESS	CÂBLAGE MICROINTERRUPTEUR DE FREIN	VERKABELUNG BREMS MIKROSCHALTER	CABLEADO MICROINTERRUPTOR FRENO

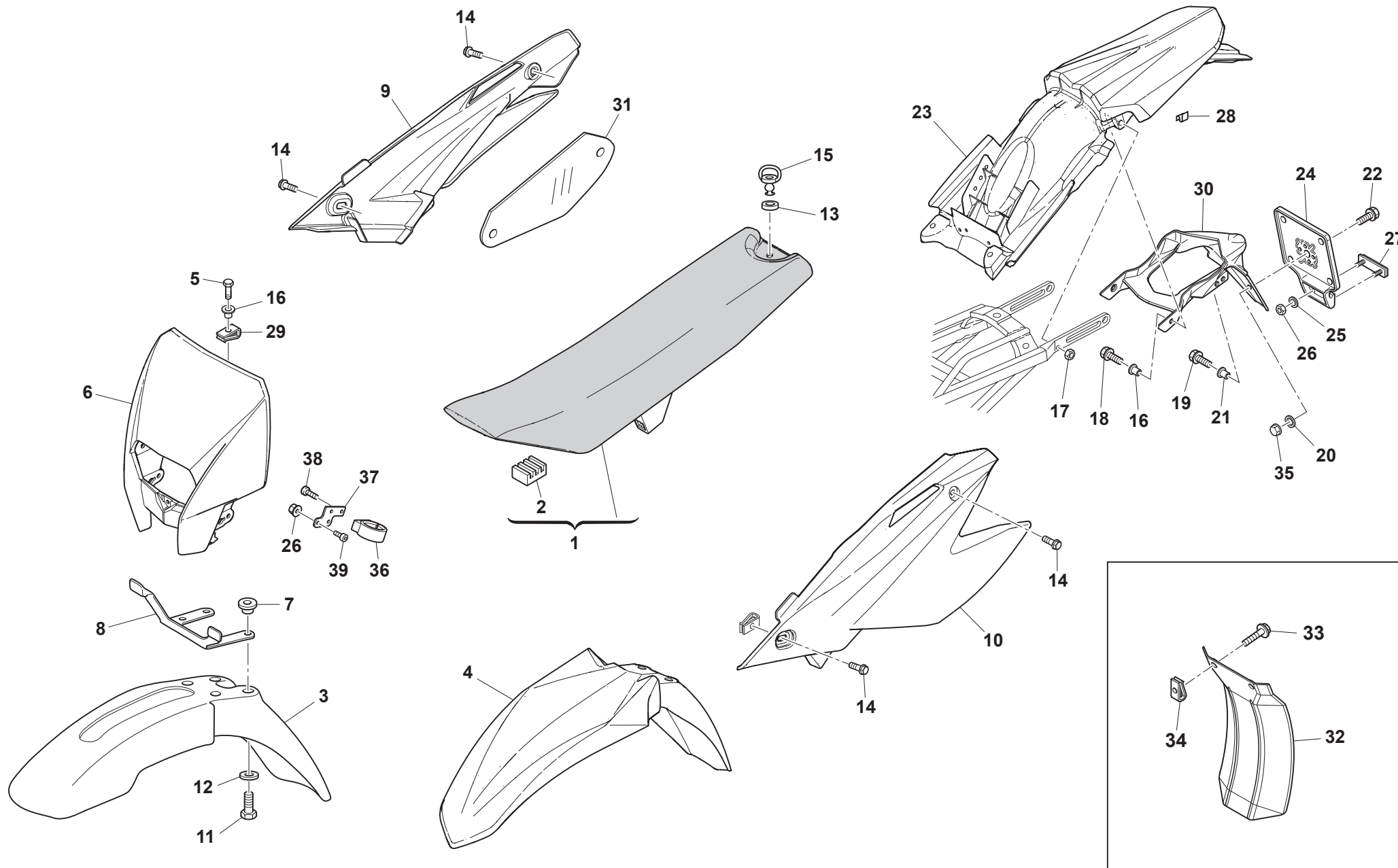



RS 125R/2017
SM 125R/2017

PANNELLI, PARAFANGHI, SELLA, PORTATARGA - PANEL, FENDERS, SEAT, PLATE HOLDER
PANNEAU, GARDE-BOUES, SIEGE, PORTE-BALAI - STREIFEN, KOTFLUGEL, SATTEL, SCHILDTRÄGER
PANELO, GUARDABARROS, SILLIN, PORTAMATRICULA

TAVOLA
DRAWING
TABLE
BILD
TABLA

24

Note Notes Notes Marke Notas	Pos. No. N. Index Pos.	N. Cod. Code No. Nr. Code Code Nr N. Cod.	Q.tà Q.ty Q.te M.ge C.ad	DENOMINAZIONE	NAME	DESIGNATION	BESHREIBUNG	DENOMINACION
	1	F000A01628	1	SELLA	SADDLE	SELLE	SITZBANK	ASIENTO
	2	86610191A	1	TAMPONE	PAD	TAMPON	PUFFER	TACO
SM 125R	3	8AC0H0525	1	PARAFANGO ANTERIORE	FRONT MUDGUARD	GARDE-BOUE AVANT	VORDERRADKOTFLÜGEL	GUARDABARROS DELANTERO
RS 125R	4	F000P00156	1	PARAFANGO ANTERIORE	FRONT MUDGUARD	GARDE-BOUE AVANT	VORDERRADKOTFLÜGEL	GUARDABARROS DELANTERO
	5	Z00062727	1	VITE TEF M6x16	FLANGED EXAGON HEAD SCREW M6x16	BOULON DE BRIDE M6x16	FLANSCHENSCHRAUBE M6x16	TORNILLO DE REBORDE M6x16
A	6	FA00A00227	1	CUPOLINO	FRONT FAIRING	NEZ DE CARÉNAGE	WINDSCHUTZSCHEIBE	CÚPULA
B	6	FB00A00227	1	CUPOLINO	FRONT FAIRING	NEZ DE CARÉNAGE	WINDSCHUTZSCHEIBE	CÚPULA
RS 125R	7	Z00069429	4	BUSSOLA Ø9xØ7x4,8	BUSHING Ø9xØ7x4,8	DOUILLE Ø9xØ7x4,8	BUCHSE Ø9xØ7x4,8	CASQUILLO Ø9xØ7x4,8
SM 125R	7	ZC0069429	4	BUSSOLA Ø9xØ7x9,5	BUSHING Ø9xØ7x9,5	DOUILLE Ø9xØ7x9,5	BUCHSE Ø9xØ7x9,5	CASQUILLO Ø9xØ7x9,5
	8	8000A6644	1	SUPPORTO CUPOLINO	FRONT FAIRING SUPPORT	SUPPORT DE NEZ DE CARÉNAGE	WINDSCHUTZSCHEIBE HALTERUNG	SOPORTE CÚPULA
A	9	F000A01679	1	FIANCHETTO DESTRO	COVER, FRAME R.H.	COUVERCLE CADRE DROIT	SEITENDECKEL, RECHTS	CUBIERTA BASTIDOR DERECHA
B	9	F000A01687	1	FIANCHETTO DESTRO	COVER, FRAME R.H.	COUVERCLE CADRE DROIT	SEITENDECKEL, RECHTS	CUBIERTA BASTIDOR DERECHA
B	10	F000A01697	1	FIANCHETTO SINISTRO	COVER, FRAME L.H.	COUVERCLE CADRE GAUCHE	SEITENDECKEL, LINKS	CUBIERTA BASTIDOR IZQUERDA
A	10	F000A01848	1	FIANCHETTO SINISTRO	COVER, FRAME L.H.	COUVERCLE CADRE GAUCHE	SEITENDECKEL, LINKS	CUBIERTA BASTIDOR IZQUERDA
RS 125R	11	Z00062728	4	VITE TEF [M6x20]	FLANGED EXAGON HEAD SCREW [M6x20]	BOULON DE BRIDE [M6x20]	SCHRAUBE [M6x20]	TORNILLO [M6x20]
SM 125R	11	Z00062729	4	VITE TEF M6x25	FLANGED EXAGON HEAD SCREW M6x25	BOULON DE BRIDE M6x25	FLANSCHENSCHRAUBE M6x25	TORNILLO DE REBORDE M6x25
	12	Z00048814	4	ROSETTA Ø18xØ6,4	WASHER Ø18xØ6,4	RONDELLE Ø18xØ6,4	UNTERLEGSCHIEBE Ø18xØ6,4	ARANDELA Ø18xØ6,4
	13	800069149	2	ROSETTA Ø17xØ9	WASHER Ø17xØ9	RONDELLE Ø17xØ9	UNTERLEGSCHIEBE Ø17xØ9	ARANDELA Ø17xØ9
	14	8B00A8421	4	VITE TEF M5x16	FLANGED EXAGON HEAD SCREW M5x16	BOULON DE BRIDE M5x16	FLANSCHENSCHRAUBE M5x16	TORNILLO DE REBORDE M5x16
	15	8000H1917	1	PERNO D'ATTACCO SELLA	SADDLE ATTACHMENT PIN	AXE D'ATTACHE SELLE	BOLZEN SITZBANK	EJE DE FIJACIÓN ASIENTO
	16	Z00069429	3	BUSSOLA Ø9xØ7x4,8	BUSHING Ø9xØ7x4,8	DOUILLE Ø9xØ7x4,8	BUCHSE Ø9xØ7x4,8	CASQUILLO Ø9xØ7x4,8
	17	Z00044240	2	DADO AUTOBLOCCANTE M6	SELF-LOCKING NUT M6	ECROU AUTOBLOQUANT M6	SELBSTSICHERNDE MUTTER M6	TUERCA AUTOBLOCCANTE M6
	18	ZPA067545	2	VITE TEF M6x22	FLANGED EXAGON HEAD SCREW M6x22	BOULON DE BRIDE M6x22	FLANSCHENSCHRAUBE M6x22	TORNILLO DE REBORDE M6x22
	19	Z00062728	2	VITE TEF M6x20	FLANGED EXAGON HEAD SCREW M6x20	BOULON DE BRIDE M6x20	SCHRAUBE M6x20	TORNILLO M6x20
	20	62ND15549	2	ROSETTA	WASHER	RONDELLE	UNTERLEGSCHIEBE	ARANDELA
	21	ZB0069429	2	BUSSOLA Ø15,9xØ8,9xØ6,9	BUSHING Ø15,9xØ8,9xØ6,9	DOUILLE Ø15,9xØ8,9xØ6,9	BUCHSE Ø15,9xØ8,9xØ6,9	CASQUILLO Ø15,9xØ8,9xØ6,9
	22	Z00062727	2	VITE TEF M6x16	FLANGED EXAGON HEAD SCREW M6x16	BOULON DE BRIDE M6x16	FLANSCHENSCHRAUBE M6x16	TORNILLO DE REBORDE M6x16
RS 125R	23	F000P01366	1	PARAFANGO POSTERIORE	REAR MUDGUARD	GARDE-BOUE ARRIÈRE	HINTERRADKOTFLÜGEL	GUARDABARROS TRASERO
SM 125R	23	F000P01367	1	PARAFANGO POSTERIORE	REAR MUDGUARD	GARDE-BOUE ARRIÈRE	HINTERRADKOTFLÜGEL	GUARDABARROS TRASERO
	24	8000H3018	1	PIASTRA PORTATARGA	NUMBER PLATE HOLDER	SUPPORT PLAQUE D'IMM.	NUMMERNSCHILDHALTER	PORTAMATRICULA
	25	62ND15547	2	ROSETTA	WASHER	RONDELLE	UNTERLEGSCHIEBE	ARANDELA
	26	Z00040717	4	DADO AUTOBLOCCANTE M4	SELF-LOCKING NUT M4	ECROU AUTOBLOQUANT M4	SELBSTSICHERNDE MUTTER M4	TUERCA AUTOBLOCCANTE M4
	27	800073834	1	CATADIOTTRO CON FILETTO	REFLECTOR	CATADIOPTRE	RÜCKSTRAHLER	CATADIÓPTRICO

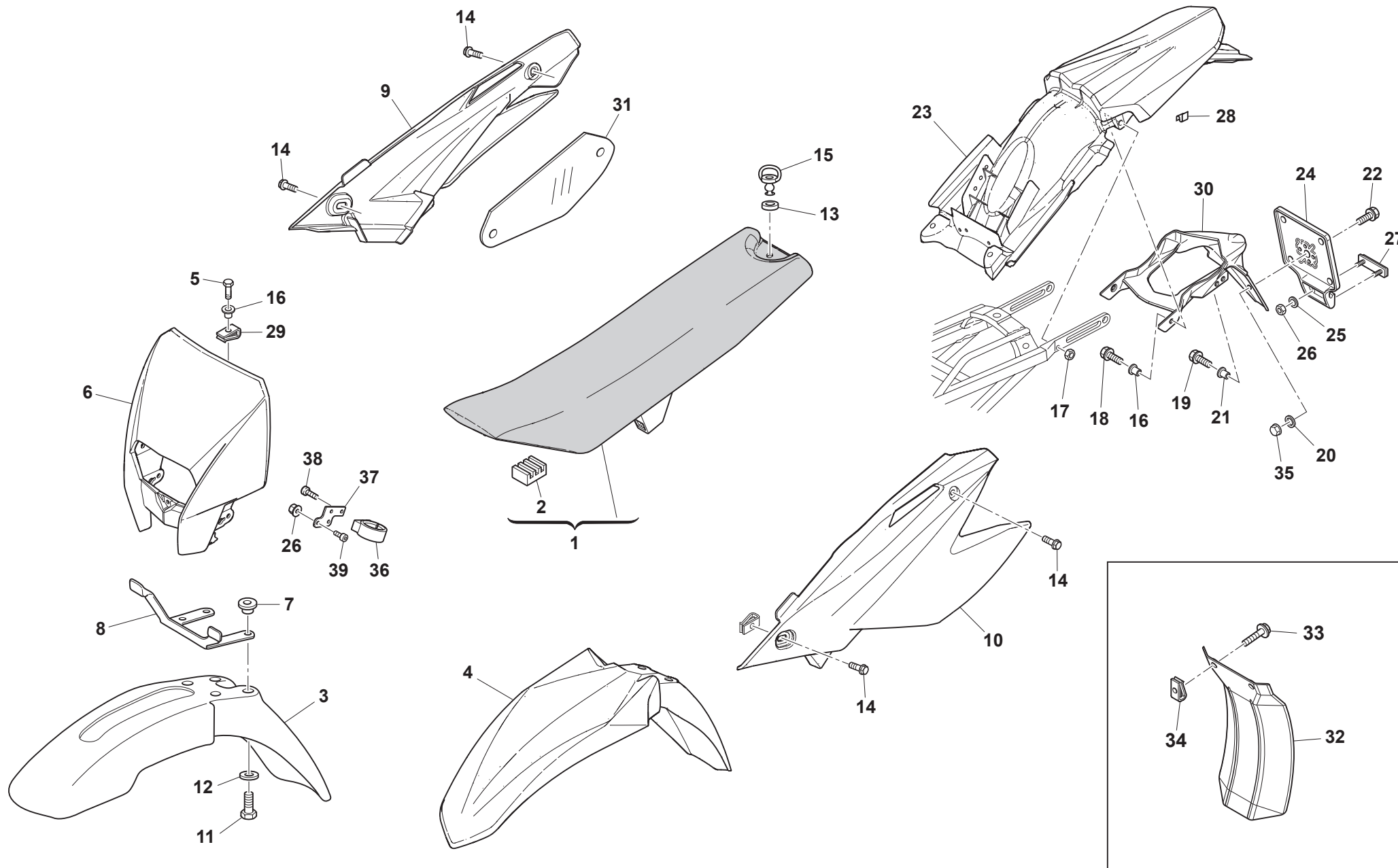

Note Notes Notes Marke Notas	Pos. No. N. Index Pos.	N. Cod. Code No. Nr. Code Code Nr N. Cod.	Q.tà Q.ty Q.te M.ge C.ad	DENOMINAZIONE	NAME	DESIGNATION	BESHREIBUNG	DENOMINACION
	28	800072494	1	MOLLETTA FERMACAVO	WIRE CLAMP	COLLIER, CORDON	KABELBINDER	GRAMPA CORDON
	29	F000P01706	1	PIASTRINA	PLATE	PLAQUETTE	PLÄTTCHEN	PLACA
	30	8000H1405	1	PARAFANGO POSTERIORE PORTATARGA	FENDER, REAR NUMBER PLATE HOLDER	GARDE-BOUE ARRIERE PORTE-PLAQUE	KOTFLUEGEL HINTEN KENNZEICHEN	GUARDABARROS TRASERO PORTA-MATRICULA
	31	F000P00241	1	TERMORIFLETTENTE	HEAT-REFLECTING	ISOLANT THERMIQUE	HITZEREFLKTIERENDER SCHUTZ	TERMORREFLECTANTE
	32	800069551	1	PROTEZIONE AMMORTIZZATORE	SHOCK ABSORBER PROTECTION	PROTECTION AMORTISSEUR	SCHUTZ STOßDÄMPFER	PROTECCIÓN AMORTIGUADOR
	33	8A00A8421	2	VITE TE M5x12	SCREW TE M5x12	VIS TE M5x12	SCHRAUBE TE M5x12	TORNILLO TE M5x12
	34	U00055134	2	DADO A GRAFFETTA M5	CLIP NUT M5	ECROU À AGRAFE M5	SICHERUNGSMUTTER M5	TUERCA DE CLIP M5
	35	Z00044240	2	DADO AUTOBLOCCANTE M6	SELF-LOCKING NUT M6	ECROU AUTOBLOQUANT M6	SELBSTSICHERNDE MUTTER M6	TUERCA AUTOBLOCANTE M6
	36	8000A0864	1	ANELLO GUIDA TUBO	PIPE GUIDE RING	BAGUE DE GUIDE TUBE	ROHRFÜHRUNG RING	ANILLO GUÍA TUBO
	37	U00046893	1	DADO A GRAFFETTA M6	CLIP NUT M6	ECROU À AGRAFE M6	SICHERUNGSMUTTER M6	TUERCA DE CLIP M6
	38	ZA0037283	2	VITE AUTOFILETTANTE	SCREW, TAPPING	VIS TARAUD	GEWINDESCHRAUBE	TORNILLO AUTOROSCANTE
	39	60ND02461	2	VITE TCEI M4x10	SCREW TCEI M4x10	VIS TCEI M4x10	SCHRAUBE TCEI M4x10	TORNILLO TCEI M4x10

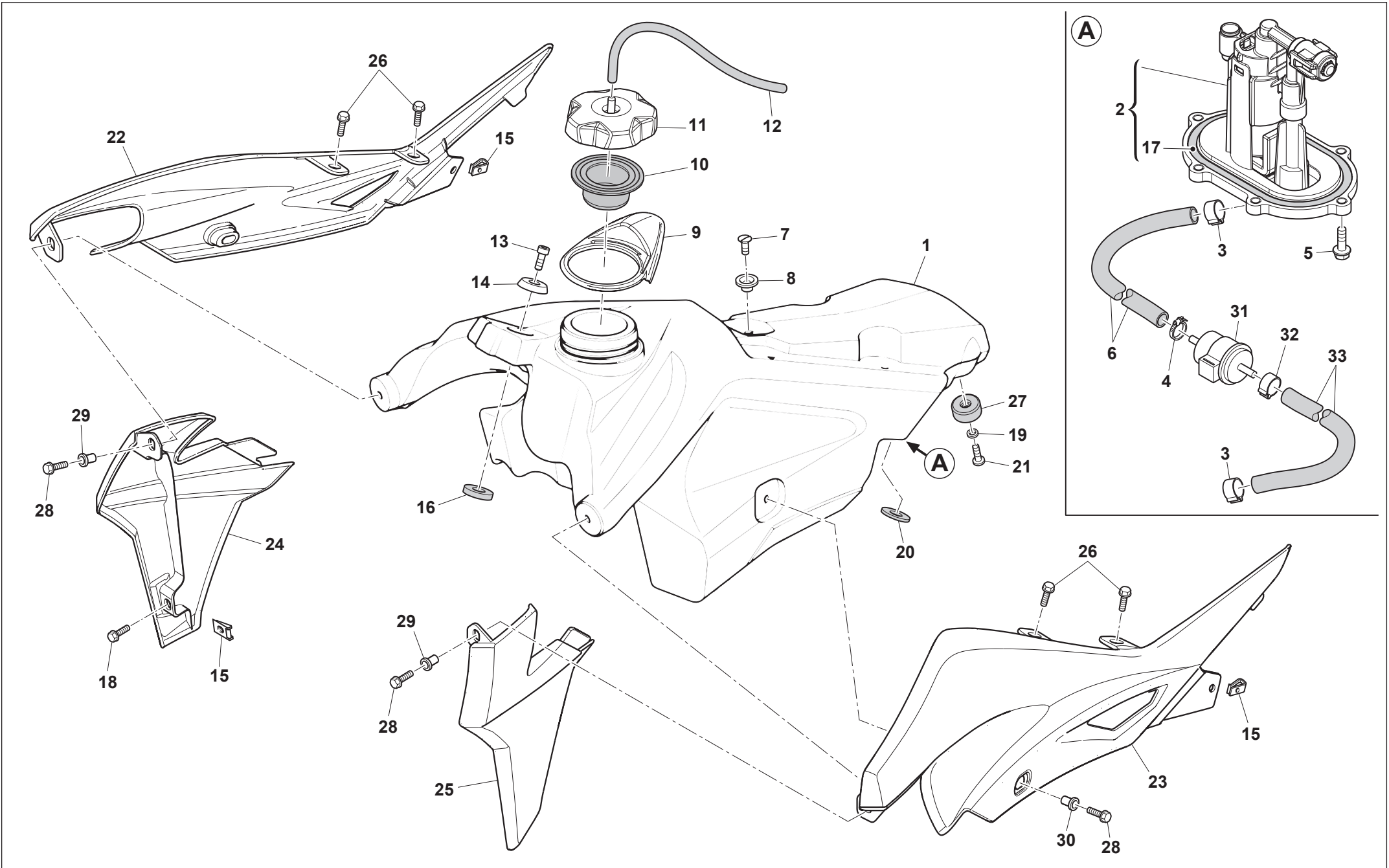



RS 125R/2017
SM 125R/2017

SERBATOIO CARBURANTE, CONVOGLIATORI - GAS TANK, PANEL
RESERVOIR CARBURANT, FLANC - KRAFTSTOFFBEHALTER, FLANKE
DEPOSITO GASOLINA, LATERAL

TAVOLA
DRAWING
TABLE
BILD
TABLA

25

Note Notes Notes Marke Notas	Pos. No. N. Index Pos.	N. Cod. Code No. Nr. Code Code Nr N. Cod.	Q.tà Q.ty Q.te M.ge C.ad	DENOMINAZIONE	NAME	DESIGNATION	BESHREIBUNG	DENOMINACION
	1	F000P01258	1	SERBATOIO CARBURANTE	FUEL TANK	RÉSERVOIR DE CARBURANT	KRAFTSTOFFTANK	DEPÓSITO COMBUSTIBLE
	2	F000P01365	1	POMPA BENZINA	FUEL PUMP	POMPE À CARBURANT	BENZINPUMPE	BOMBA GASOLINA
	3	8Z0092249	2	FASCETTA	CLAMP	COLLIER	SHELLE	ABRAZADERA
	4	8E0091687	1	FASCETTA INOX	INOX CLAMP	COLLIER	SHELLE	ABRAZADERA
	5	ZA0067997	6	VITE TEF M5x16	FLANGED EXAGON HEAD SCREW M5x16	BOULON DE BRIDE M5x16	FLANSCHENSCHRAUBE M5x16	TORNILLO DE REBORDE M5x16
	6	F000P01557	1	TUBO MANDATA	DELIVERY PIPE	TUYAU DE REFOULEMENT	VORLAUFROHR	TUBO ALIMENTACIÓN
	7	60ND04134	1	VITE TSCI M6x20	SCREW TSCI M6x20	VIS TSCI M6x20	SCHRAUBE TSCI M6x20	TORNILLO TSCI M6x20
	8	800066238	1	DISTANZIALE	SPACER	ENTRETOISE	ABSTANDHALTER	DISTANCIADOR
	9	8000B1390	1	PROTEZIONE TAPPO	PLUG GUARD	PROTECTION BOUCHON	SCHUTZ	PROTECCION TAPON
	10	8000A4562	1	GUARNIZIONE	GASKET	JOINT	DICHTUNG	JUNTA
	11	8000B1057	1	TAPPO SERBATOIO	TANK CAP	BOUCHON RESERVOIR	TANKDECKEL	TAPON DEPÓSITO
	12	8T0068873	1	TUBO	PIPE	TUBE	ROHR	TUBO
	13	60ND07335	1	VITE TCEI M6x16	SCREW TCEI M6x16	VIS TCEI M6x16	SCHRAUBE TCEI M6x16	TORNILLO TCEI M6x16
	14	8000A5678	1	ROSETTA	WASHER	RONDELLE	UNTERLEGSCHLEIBE	ARANDELA
	15	U00055134	4	DADO A GRAFFETTA M5	CLIP NUT M5	ECROU À AGRAFE M5	SICHERUNGSMUTTER M5	TUERCA DE CLIP M5
	16	800061362	1	ROSETTA	WASHER	RONDELLE	UNTERLEGSCHLEIBE	ARANDELA
	17	F000P02034	1	ANELLO OR	O-RING	JOINT TORIQUE	O-RING	JUNTA TORICA
	18	8A00A8421	2	VITE TE M5x12	SCREW TE M5x12	VIS TE M5x12	SCHRAUBE TE M5x12	TORNILLO TE M5x12
	19	8B00A0680	2	DISTANZIALE	SPACER	ENTRETOISE	ABSTANDHALTER	DISTANCIADOR
	20	8A0061362	2	ROSETTA IN GOMMA	RUBBER WASHER	RONDELLE EN CAOUTCHOUC	GUMMIUNTERLEGSCHLEIBE	ARANDELA DE GOMA
	21	Z00037745	2	VITE AUTOFILLETANTE	SCREW, TAPPING	VIS TARAUD	GEWINDESCHRAUBE	TORNILLO AUTOROSCANTE
A	22	F000A01677	1	CONVOGLIATORE DESTRO	COVER, RADIATOR, R.H.	OUIE RADIATEUR DROIT	RECHTES LEITBLECH	PROTECTOR RADIADOR DERECHO
B	22	FA00A01677	1	CONVOGLIATORE DESTRO	COVER, RADIATOR, R.H.	OUIE RADIATEUR DROIT	RECHTES LEITBLECH	PROTECTOR RADIADOR DERECHO
A	23	F000A01676	1	CONVOGLIATORE SINISTRO	COVER, RADIATOR, L.H.	OUIE RADIATEUR GAUCHE	LINKES LEITBLECH	DEFLECTOR AIRE IZQUERDO
B	23	FA00A01676	1	CONVOGLIATORE SINISTRO	COVER, RADIATOR, L.H.	OUIE RADIATEUR GAUCHE	LINKES LEITBLECH	DEFLECTOR AIRE IZQUERDO
RS 125R - A	24	F000A01836	1	PROTEZIONE RADIATORE DESTRA	COVER RADIATOR R.H.	PROTECTION RADIATEUR DROIT	KUEHLERSCHUTZ, RECHTS	PROTECCION RADIADOR DERECHO
SM 125R - A	24	F000A01837	1	PROTEZIONE RADIATORE DESTRA	COVER RADIATOR R.H.	PROTECTION RADIATEUR DROIT	KUEHLERSCHUTZ, RECHTS	PROTECCION RADIADOR DERECHO
RS 125R - B	24	F000A01840	1	PROTEZIONE RADIATORE DESTRA	COVER RADIATOR R.H.	PROTECTION RADIATEUR DROIT	KUEHLERSCHUTZ, RECHTS	PROTECCION RADIADOR DERECHO
SM 125R - B	24	F000A01841	1	PROTEZIONE RADIATORE DESTRA	COVER RADIATOR R.H.	PROTECTION RADIATEUR DROIT	KUEHLERSCHUTZ, RECHTS	PROTECCION RADIADOR DERECHO
RS 125R - A	25	F000A01838	1	PROTEZIONE RADIATORE SINISTRA	COVER RADIATOR L.H.	PROTECTION RADIATEUR GAUCHE	KUEHLERSCHUTZ, LINKS	PROTECCION RADIADOR IZQUERDO
SM 125R - A	25	F000A01839	1	PROTEZIONE RADIATORE SINISTRA	COVER RADIATOR L.H.	PROTECTION RADIATEUR GAUCHE	KUEHLERSCHUTZ, LINKS	PROTECCION RADIADOR IZQUERDO
RS 125R - B	25	F000A01842	1	PROTEZIONE RADIATORE SINISTRA	COVER RADIATOR L.H.	PROTECTION RADIATEUR GAUCHE	KUEHLERSCHUTZ, LINKS	PROTECCION RADIADOR IZQUERDO
SM 125R - B	25	F000A01843	1	PROTEZIONE RADIATORE SINISTRA	COVER RADIATOR L.H.	PROTECTION RADIATEUR GAUCHE	KUEHLERSCHUTZ, LINKS	PROTECCION RADIADOR IZQUERDO

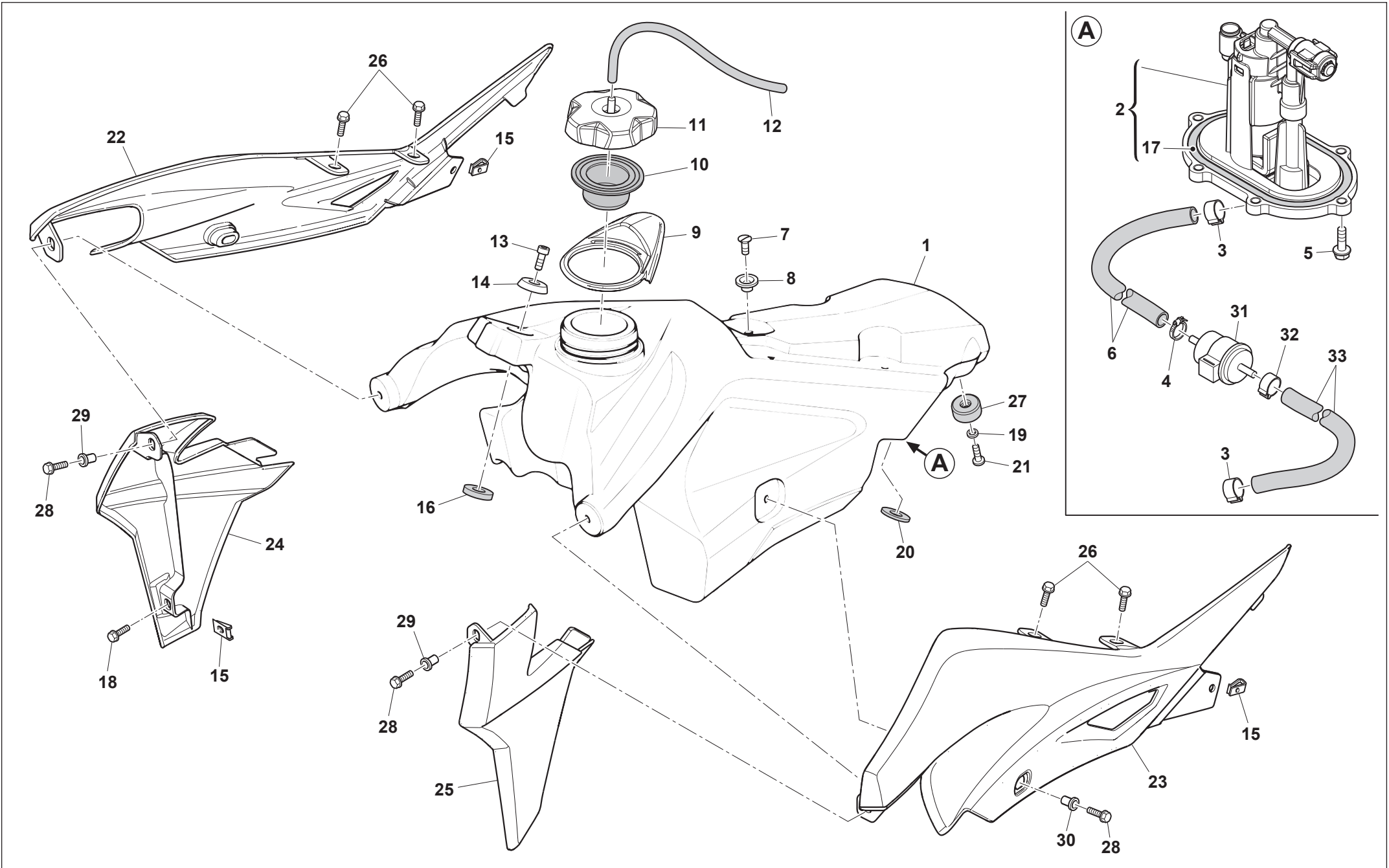

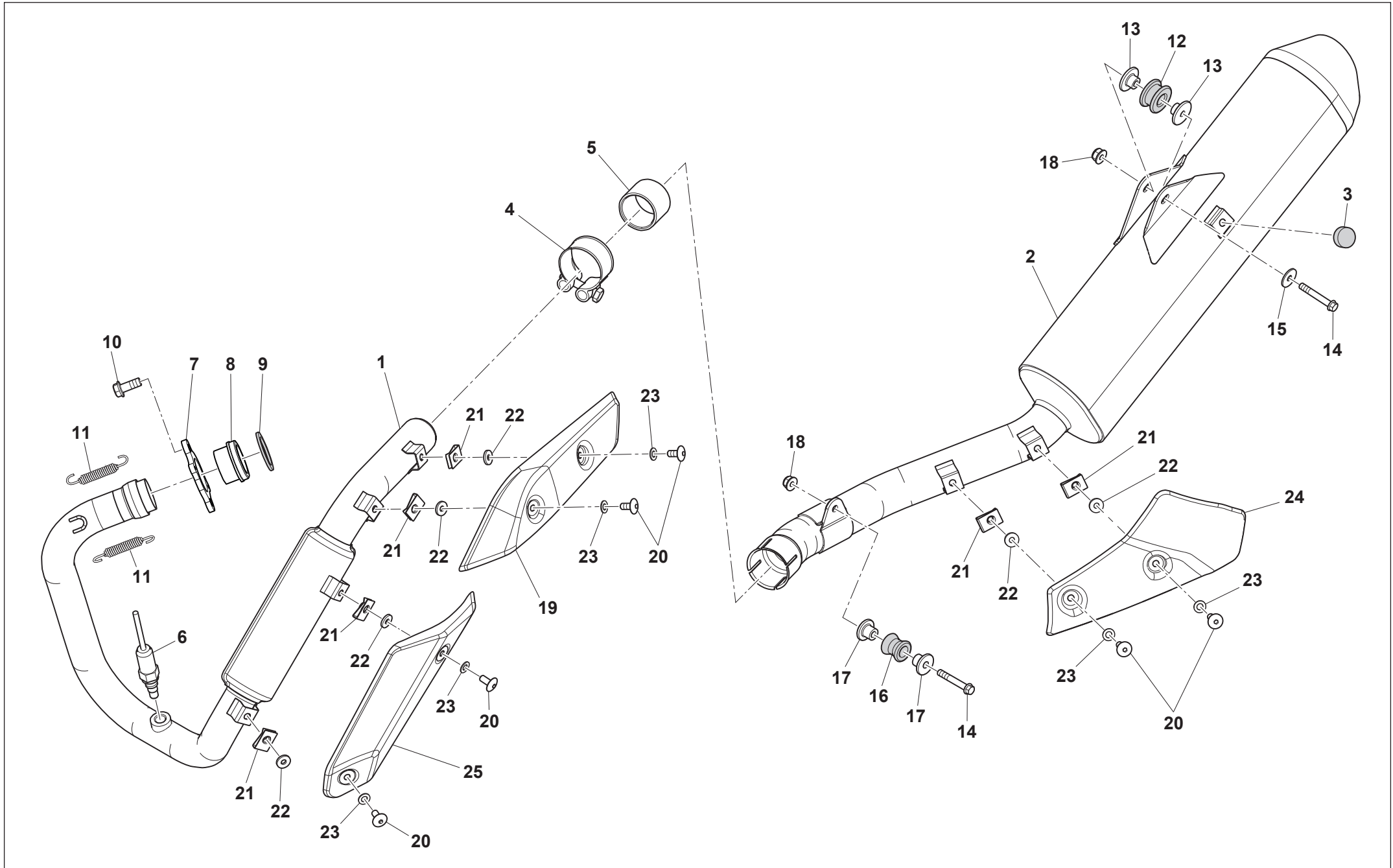



RS 125R/2017
SM 125R/2017

SCARICO - EXHAUST SYSTEM
TUYAU D'ÉCHAPPEMENT - AUSPUFFROHR
TUBO DE ESCAPE

TAVOLA
DRAWING
TABLE
BILD
TABLA

26

Note Notes Notes Marka Notas	Pos. No. Index Pos.	N. Cod. Code No. Nr. Code Code Nr N. Cod.	Q.tà Q.ty Q.te M.ge C.ad	DENOMINAZIONE	NAME	DESIGNATION	BESHREIBUNG	DENOMINACION
	1	F000P01337	1	COLLETTORE DI SCARICO	EXHAUST MUFFLER	COLLECTEUR	KRÜMMER	COLECTOR
	2	F000P01338	1	SILENZIATORE	SILENCER	SILENCIEUX	SCHALLDÄMPFER	SILENCIADOR
	3	800048802	1	GOMMINO	RUBBER RING	JOINT EN CAOUTCHOUC	GUMMISCHEIBE	GOMA
	4	8000H2219	1	FASCETTA	CLAMP	COLLIER	SHELLE	ABRAZADERA
	5	8000H1864	1	GUARNIZIONE	GASKET	JOINT	DICHTUNG	JUNTA
	6	F000P00856	1	SONDA LAMBDA	LAMBDA SENSOR	SONDE LAMBDA	LAMBDA-SONDE	SONDA LAMBDA
	7	F000P01374	1	FLANGIA	FLANGE	BRIDE	FLANSCH	BRIDA
	8	F000P01375	1	BOCCOLA	BUSHING	DOUILLE	BUCHSE	CASQUILLO
	9	F000P01376	1	GUARNIZIONE	GASKET	JOINT	DICHTUNG	JUNTA
	10	Z00069056	2	VITE TEF M8x20	FLANGED EXAGON HEAD SCREW M8x20	BOULON DE BRIDE M8x20	FLANSCHENSCHRAUBE M8x20	TORNILLO DE REBORDE M8x20
	11	8000A1239	2	MOLLA SCARICO	OUTLET SPRING	RESSORT ECHAPPEMENT	FEDER AUSLASS	MUELLE ESCAPE
	12	800089302	1	ANTIVIBRANTE	SILENT-BLOCK	ANTIVIBRATION	SCHWINGUNGSDÄMFER	ANTIVIBRADOR
	13	8C00A7729	2	DISTANZIALE	SPACER	ENTRETOISE	ABSTANDHALTER	DISTANCIADOR
	14	ZE0067545	2	VITE TEF M6x40	FLANGED EXAGON HEAD SCREW M6x40	BOULON DE BRIDE M6x40	SCHRAUBE M6x40	TORNILLO M6x40
	15	800022271	2	ROSETTA	WASHER	RONDELLE	UNTERLEGSCHIEBE	ARANDELA
	16	8000H0064	1	SILENT-BLOCK	SILENT-BLOCK	SILENT-BLOCK	SILENT-BLOCK	SILENT-BLOCK
	17	8000B0263	2	DISTANZIALE	SPACER	ENTRETOISE	ABSTANDHALTER	DISTANCIADOR
	18	Z00044240	2	DADO AUTOBLOCCANTE M6	SELF-LOCKING NUT M6	ECROU AUTOBLOQUANT M6	SELBSTSICHERNDE MUTTER M6	TUERCA AUTOBLOCANTE M6
	19	F000P01525	1	PROTEZIONE CALORE COLLETTORE	HEAT-PROTECTING COVER	PROTECTION CHALEUR	HITZSCHUTZ	PROTECCIÓN CALOR
	20	Z00055703	6	VITE TCEI M6x14	SCREW TCEI M6x14	VIS TCEI M6x14	SCHRAUBE TCEI M6x14	TORNILLO TCEI M6x14
	21	U00046893	6	DADO A GRAFFETTA M6	CLIP NUT M6	ECROU À AGRAFE M6	SICHERUNGSMUTTER M6	TUERCA DE CLIP M6
	22	800035112	6	ROSETTA	WASHER	RONDELLE	UNTERLEGSCHIEBE	ARANDELA
	23	62N115504	6	ROSETTA	WASHER	RONDELLE	UNTERLEGSCHIEBE	ARANDELA
	24	F000P01526	1	PROTEZIONE CALORE SILENZIATORE	HEAT-PROTECTING COVER	PROTECTION CHALEUR	HITZSCHUTZ	PROTECCIÓN CALOR
	25	F000P01627	1	PROTEZIONE CALORE	HEAT-PROTECTING COVER	PROTECTION CHALEUR	HITZSCHUTZ	PROTECCIÓN CALOR

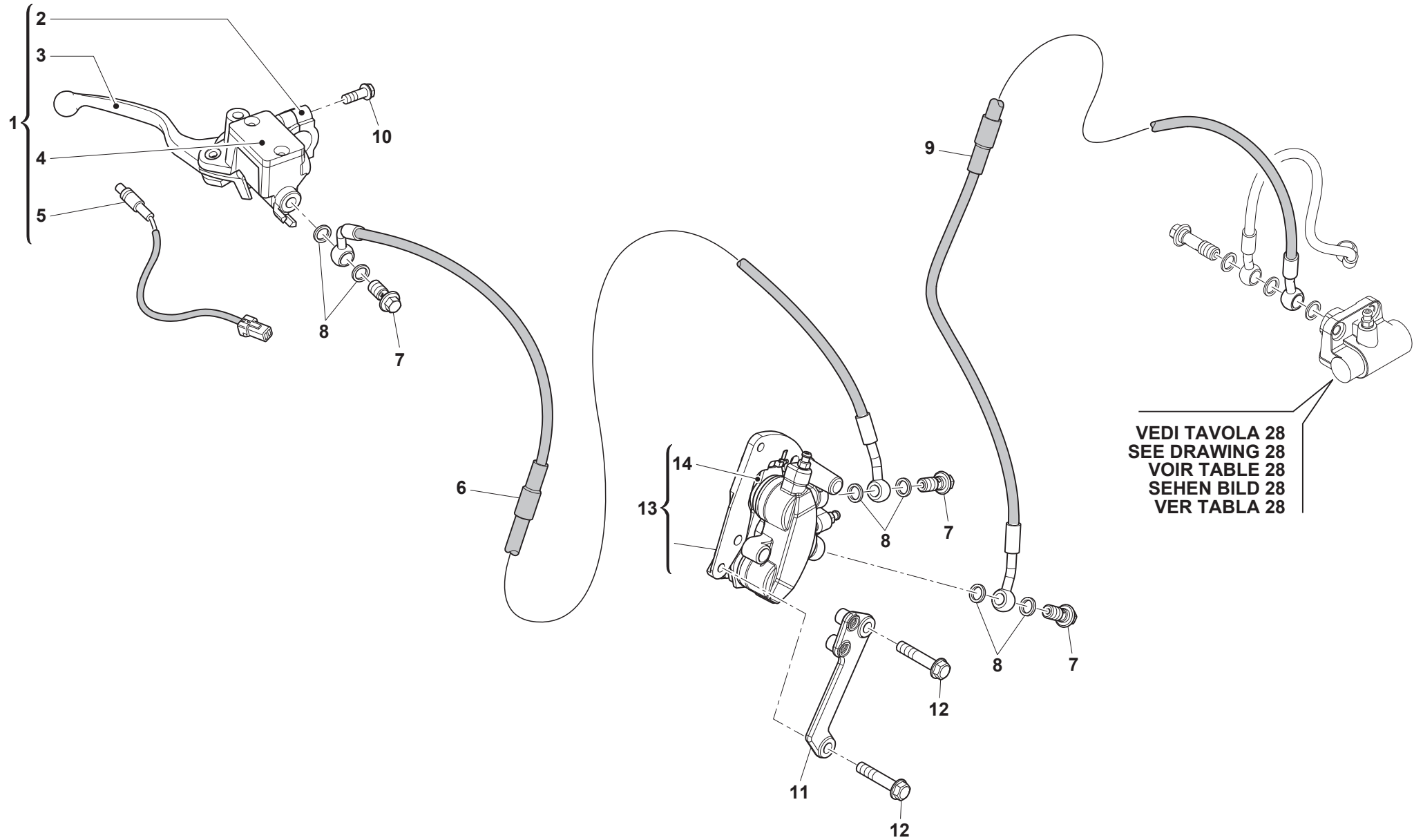

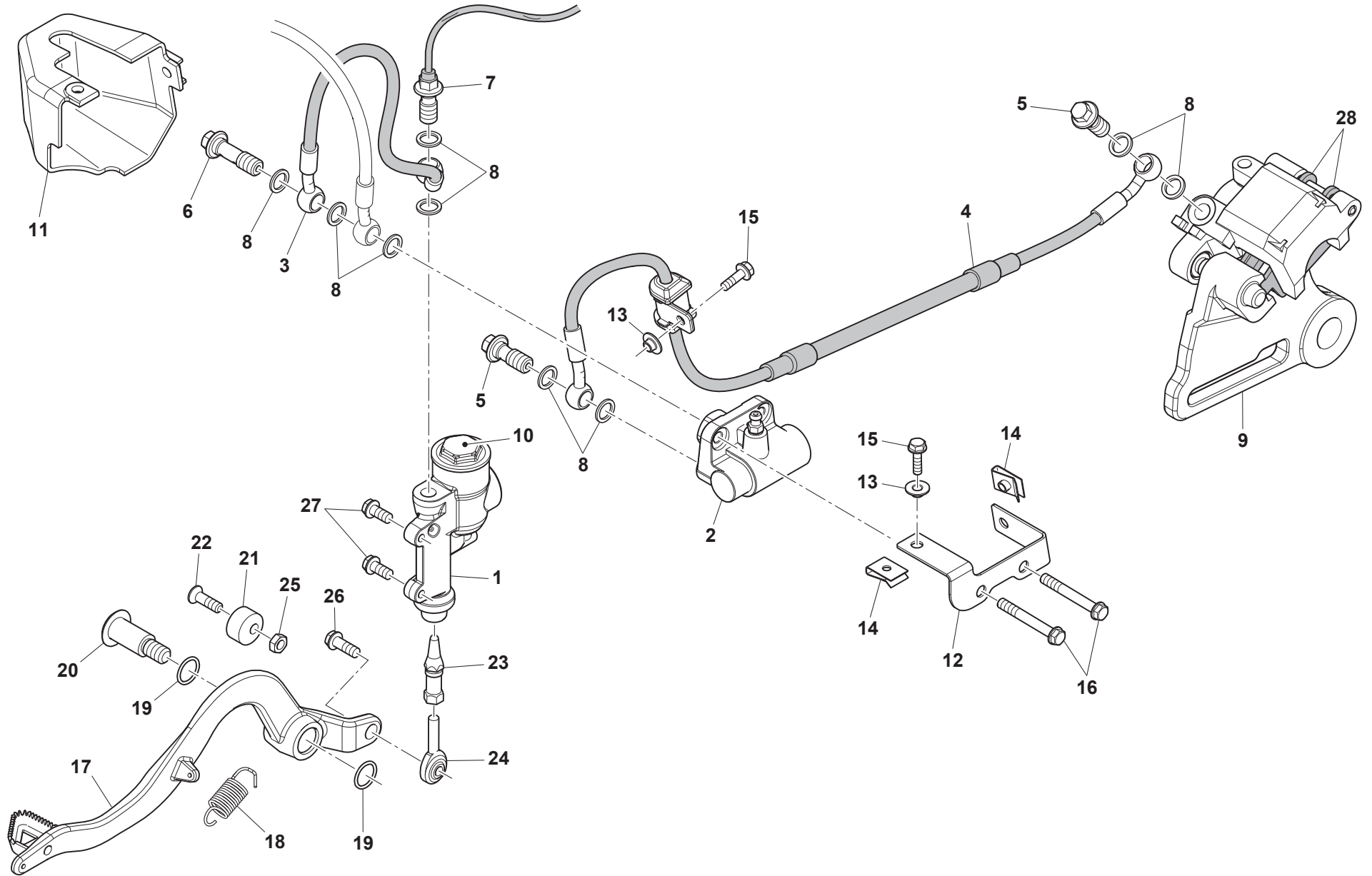



RS 125R/2017
SM 125R/2017

FRENO IDRAULICO POSTERIORE - REAR HYDRAULIC BRAKE
FREIN HYDRAULIQUE ARRIERE - HINTERBREMSE
FRENO HIDRAULICO TRASERO

TAVOLA
DRAWING
TABLE
BILD
TABLA

28

Note Notes Notes Marke Notas	Pos. No. N. Index Pos.	N. Cod. Code No. Nr. Code Code Nr N. Cod.	Q.tà Q.ty Q.te M.ge C.ad	DENOMINAZIONE	NAME	DESIGNATION	BESHREIBUNG	DENOMINACION
	1	F000A01294	1	POMPA FRENO POSTERIORE	REAR BRAKE PUMP	MAÎTRE-CYLINDRE DE FREIN	ZUSAMMENBAU HAUPTBREMSZYLINDER	CONJUNTO BOMBA FRENO
	2	F000P01295	1	RIPARTITORE DI FRENATA CBS	DISTRIBUTION FRAME BRAKING	REPARTITEUR POUR LE FREINAGE	VERTEILER FÜR BREMSE	RED DE DISTRIBUCION PARA FRENADO
	3	F000P01296	1	TUBO POMPA - CBS	CBS - PUMP PIPE	TUYAU POMPE - CBS	ROHR PUMPE - CBS	TUBO BOMBA - CBS
	4	F000P01298	1	TUBO PINZA FRENO - CBS	CBS - BRAKE CALLIPER PIPE	TUYAU ETRIER DE FREIN - CBS	ROHR BREMSSELLE - CBS	TUBO PINZA FRENO - CBS
	5	F00P02044	2	VITE TE M10x19	HEXAGON SOCKET-HEAD BOLT M10x19	VIS M10x19	SCHRAUBE M10x19	TORNILLO M10x19
	6	F00P02043	1	VITE TE M10x28	HEXAGON SOCKET-HEAD BOLT M10x28	VIS M10x28	SCHRAUBE M10x28	TORNILLO M10x28
	7	F00P02042	1	INTERRUTTORE STOP POSTERIORE	REAR STOP SWITCH	INTERRUPTEUR STOP ARRIÈRE	BREMSLICHTSCHALTER	INTERRUPTOR FRENO TRASERO
	8	800021480	9	ROSETTA	WASHER	RONDELLE	UNTERLEGSSCHEIBE	ARANDELA
	9	F000A01332	1	PINZA FRENO POSTERIORE	REAR BRAKE CALLIPER	ETRIER DE FREIN ARRIERE	BREMSSELLE HINT.	PINZA FRENO TRASERO
	10	F000P02039	1	TAPPO SERBATOIO FRENO POSTERIORE	REAR BRAKE TANK CAP	BOUCHON RESERVOIR DE FREIN ARRIERE	TANKDECKEL HINTERRADBREMSE	TAPON DEPÓSITO FRENO TRASERO
	11	F000P01568	1	PROTEZIONE	PROTECTION	PROTECTION	SCHUTZ	PROTECCIÓN
	12	F000P01569	1	PIASTRINA	PLATE	PLAQUETTE	PLÄTTCHEN	PLACA
	13	800069282	2	BUSSOLA Ø14xØ5,25Ø4,8	BUSHING Ø14xØ5,25Ø4,8	DOUILLE Ø14xØ5,25Ø4,8	BUCHSE Ø14xØ5,25Ø4,8	CASQUILLO Ø14xØ5,25Ø4,8
	14	U00055134	2	DADO A GRAFFETTA	CLIP NUT	ECROU À AGRAFE	SICHERUNGSMUTTER	TUERCA DE CLIP
	15	ZA0067997	2	VITE TEF M5x16	FLANGED EXAGON HEAD SCREW M5x16	BOULON DE BRIDE M5x16	FLANSCHENSCHRAUBE M5x16	TORNILLO DE REBORDE M5x16
	16	Z00062731	2	VITE TEF M6x45	FLANGED EXAGON HEAD SCREW M6x45	BOULON DE BRIDE M6x45	SCHRAUBE M6x45	TORNILLO M6x45
	17	8B00A7634	1	PEDALE COMANDO FRENO	BRAKE CONTROL PEDAL	PÉDALE COMMANDE DE FREIN	BREMSPEDAL	PEDAL MANDO FRENO
	18	8000H5148	1	MOLLA PEDALE FRENO	RETURN SPRING	RESSORT	FEDER	MUELLE
	19	800022551	2	ANELLO OR 2056	2056 O-RING	JOINT TORIQUE 2056	O-RING 2056	JUNTA TORICA 2056
	20	Y00055902	1	VITE TPEI M10x16	BOLT TPEI M10x16	VIS TPEI M10x16	SCHRAUBE TPEI M10x16	TORNILLO TPEI M10x16
	21	8A0069125	1	CAMMA	CAM	CAME	NOCKEN	LEVA
	22	Y00055241	1	VITE TSEI M6x14	SCREW TSEI M6x14	VIS TSEI M6x14	SCHRAUBE TSEI M6x14	TORNILLO TSEI M6x14
	23	8000A7635	1	PUNTALE	PUSH ROD	EMBOUT	STIFT	PUNTA
	24	8A0076055	1	SNODO SFERICO	BALL JOINT	JOINT À ROTULE	KUGELGELENK	RÓTULA
	25	61ND15062	1	DADO M6	NUT M6	ECROU M6	MUTTER M6	TUERCA M6
	26	Z00062727	1	VITE TEF M6x16	FLANGED EXAGON HEAD SCREW M6x16	BOULON DE BRIDE M6x16	FLANSCHENSCHRAUBE M6x16	TORNILLO DE REBORDE M6x16
	27	800062726	2	VITE TEF M6x16	FLANGED EXAGON HEAD SCREW M6x16	BOULON DE BRIDE M6x16	FLANSCHENSCHRAUBE M6x16	TORNILLO DE REBORDE M6x16
	28	F000P02029	1	COPIA PASTIGLIE	PAIR OF BRAKE PADS	PAIRE PLAQUETTES	PAAR BREMSBELÄGE	PAREJA PASTILLAS

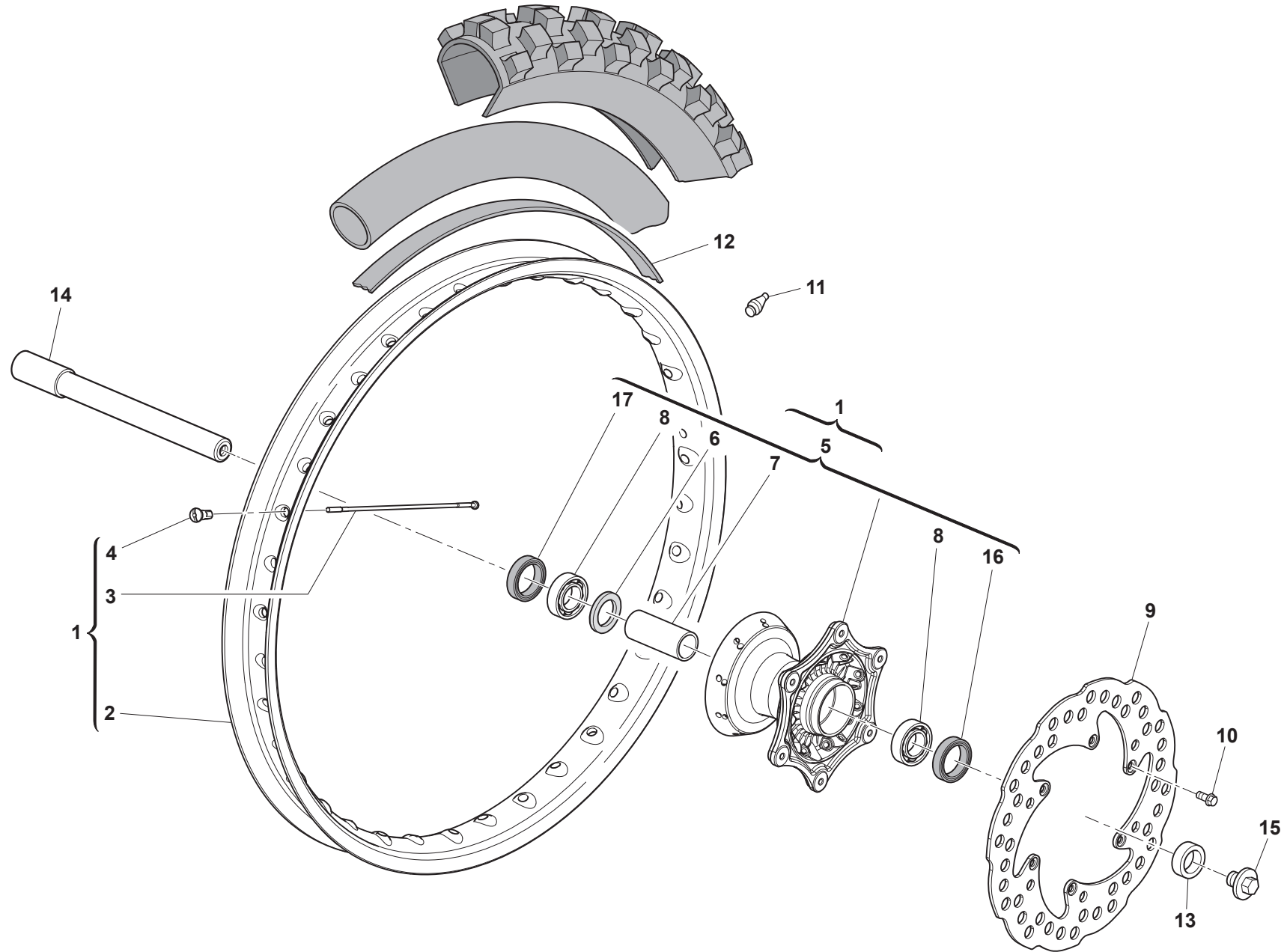



RUOTA ANTERIORE - FRONT WHEEL
ROUE AV. - VORTERRAD
RUEDA DELANTERA

Note Notes Marke Notas	Pos. No. Index Pos.	N. Cod. Code No. Nr. Code Code Nr N. Cod.	Q.tà Q.ty Q.te M.ge C.ad	DENOMINAZIONE	NAME	DESIGNATION	BESHREIBUNG	DENOMINACION
	1	F000A01317	1	RUOTA ANTERIORE SENZA PNEUMATICO	FRONT WHEEL WITHOUT TYRE	ROUE AVANT SANS PNEU	VORDERRAD OHNE TYRE	RUEDA DELANTERA SIN NEUMÁTICO
	2	F000P01318	1	CERCHIO RUOTA ANT. 1,6"x21"	FRONT WHEEL RIM 1,6"x21"	JANTE ROUE AVANT 1,6"x21"	FELGE VORDERRAD 1,6"x21"	LLANTA RUEDA DEL. 1,6"x21"
	3	F000P01319	36	RAGGIO	SPOKE	BRAS	SPEICHE	RADIO
	4	8000A6208	36	NIPPLO	NIPPLE	NIPPLE	NIPPEL	NIPLE
	5	F000A01320	1	MOZZO RUOTA ANTERIORE	FRONT WHEEL HUB	MOYEU	NABE	CUBO
	6	F000P01595	1	ANELLO DI SUPPORTO	SUPPORT RING	BAGUE DE SUPPORT	HALTERUNG RING	ANILLO DE SOPORTE
	7	F000P01596	1	DISTANZIALE INTERNO	INTERNAL SPACER	ENTRETOISE INTÉRIEUR	INTERNER ABSTANDHALTER	DISTANCIADOR INTERNO
	8	F000P02032	2	CUSCINETTO Ø47xØ20x14	BEARING Ø47xØ20x14	ROULEMENT Ø47xØ20x14	LAGER Ø47xØ20x14	COJINETE Ø47xØ20x14
	9	F000P01321	1	DISCO FRENO ANTERIORE	FRONT BRAKE DISC	DISQUE DE FREIN	BREMSSSCHEIBE	DISCO FRENO
	10	Z00062726	6	VITE	BOLT	VIS	SCHRAUBE	TORNILLO
	11	800009570	1	TAPPO	PLUG	BOUCHON	STOPFEN	TAPON
	12	800013346	1	PROTEZIONE CAMERA D'ARIA	AIR TUBE PROTECTION	VAINÉ DE PROTECTION	HULLE	VAINA DE PROTECCION
	13	F000P01322	1	DISTANZIALE	SPACER	ENTRETOISE	ABSTANDHALTER	DISTANCIADOR
	14	F000P01323	1	PERNO RUOTA ANTERIORE	FRONT WHEEL AXLE	PIVOT DE ROUE AVANT	FRONT RADASCHE	EJE RUEDA DELANTERO
	15	F000P01324	1	VITE PERNO M14	PIN BOLT M14	VIS AXE M14	SCHRAUBE BOLZEN M14	TORNILLO EJE M14
	16	F000P02037	1	PARAOILIO Ø47xØ32x7	OIL SEAL Ø47xØ32x7	JOINT PARE-HUILE Ø47xØ32x7	ÖLDICHTRING Ø47xØ32x7	RETÉN DE ACEITE Ø47xØ32x7
	17	F000P02036	1	PARAOILIO Ø47xØ25x7	OIL SEAL Ø47xØ25x7	JOINT PARE-HUILE Ø47xØ25x7	ÖLDICHTRING Ø47xØ25x7	RETÉN DE ACEITE Ø47xØ25x7

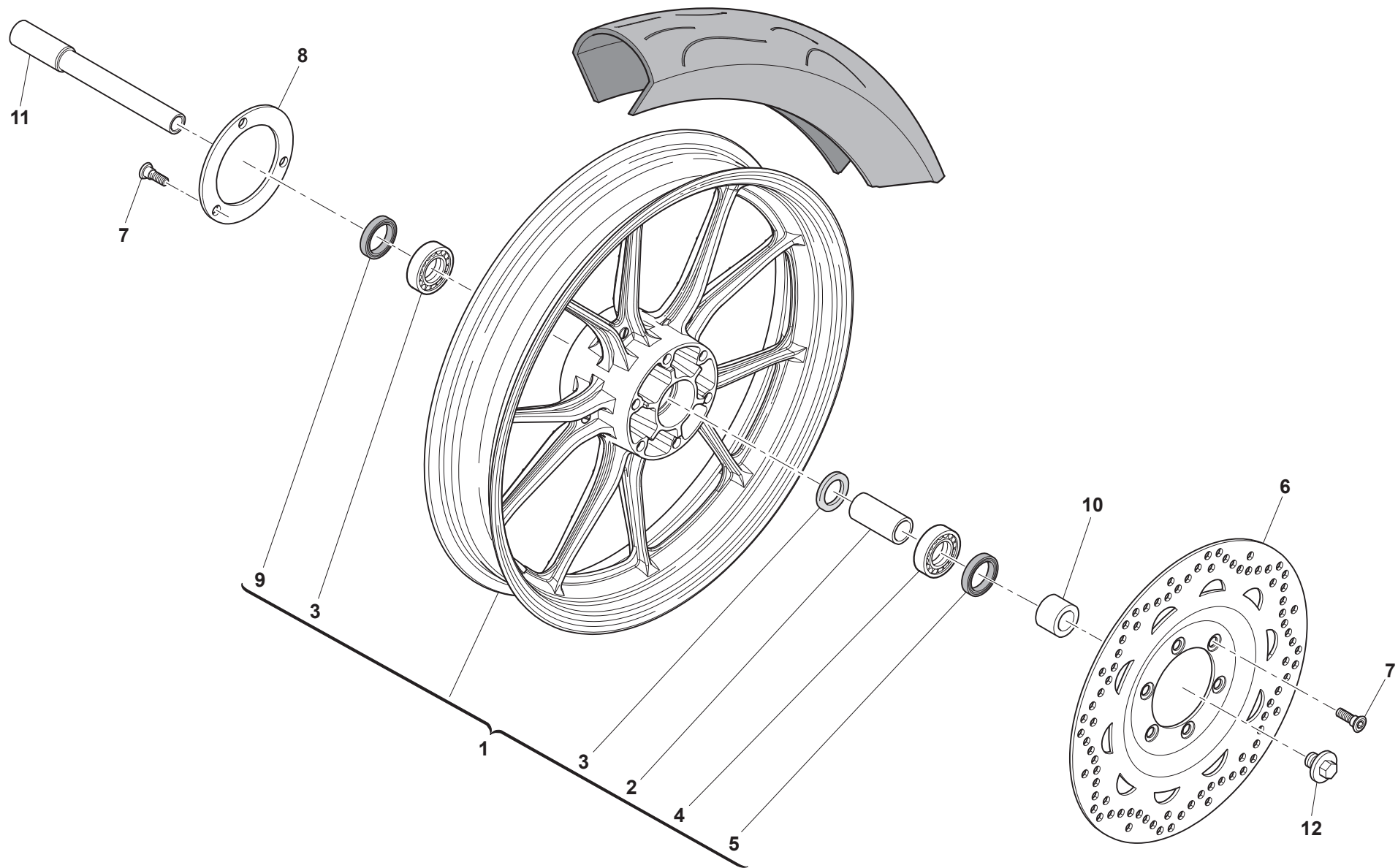

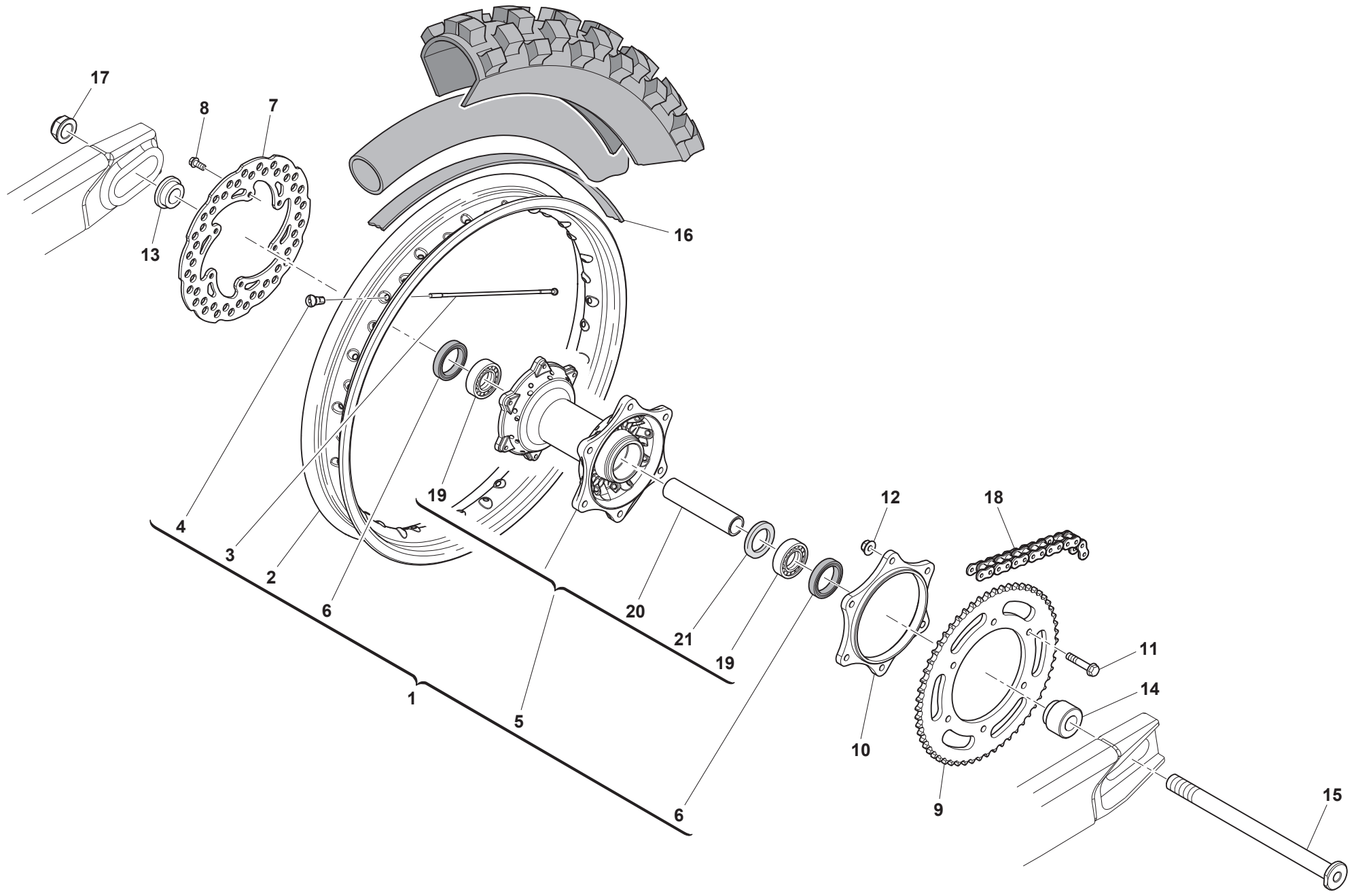



**RUOTA POSTERIORE - REAR WHEEL
ROUE ARRIERE - HINTERRAD
RUEDA TRASERA**

Note Notes Notes Marke Notas	Pos. No. Index Pos.	N. Cod. Code No. Nr. Code Code Nr N. Cod.	Q.tà Q.ty Q.te M.ge C.ad	DENOMINAZIONE	NAME	DESIGNATION	BESHREIBUNG	DENOMINACION
	1	F000A01326	1	RUOTA POSTERIORE SENZA PNEUMATICO	REAR WHEEL WITHOUT TYRE	ROUE ARRIÈRE SANS PNEU	HINTERRAD OHNE TYRE	RUEDA TRASERA SIN NEUMÁTICO
	2	F000P01327	1	CERCHIO RUOTA POST. 2,15"x18"	REAR WHEEL RIM 2,15"x18"	JANTE ROUE ARRIÈRE 2,15"x18"	FELGE HINTERRAD 2,15"x18"	LLANTA RUEDA TRAS. 2,15"x18"
	3	F000P01328	36	RAGGIO	SPOKE	BRAS	SPEICHE	RADIO
	4	8000A6209	36	NIPPLO	NIPPLE	NIPPLE	NIPPEL	NIPLE
	5	F000A01329	1	MOZZO RUOTA POSTERIORE	REAR WHEEL HUB	MOYEU	NABE	CUBO
	6	F000P02037	2	PARAOLIO Ø42xØ32x7	OIL SEAL Ø42xØ32x7	JOINT PARE-HUILE Ø42xØ32x7	ÖLDICHTRING Ø42xØ32x7	RETÉN DE ACEITE Ø42xØ32x7
	7	F000P01330	1	DISCO FRENO POSTERIORE	REAR BRAKE DISC	DISQUE DE FREIN	BREMSSCHEIBE	DISCO FRENO
	8	Z00062726	6	VITE TEF M6x14	FLANGED EXAGON HEAD SCREW M6x14	BOULON DE BRIDE M6x14	FLANSCHENSCHRAUBE M6x14	TORNILLO DE REBORDE M6x14
	9	F000P01331	1	CORONA DENTATA Z=58	CHAIN SPROCKET T=58	COURONNE DENTÉE D=58	ZAHNKRANZ Z=58	CORONA DENTADA Z=58
	10	F000P01352	1	DISTANZIALE CORONA-MOZZO	SPROCKET-HUB SPACER	ENTRETOISE COURONNE-MOYEU	ABSTANDHALTER ZAHNKRANZ-NABE	DISTANCIADOR CORONA-CUBO
	11	ZA0062733	6	VITE TE M8x40	SCREW M8x40	VIS TE M8x40	SCHRAUBE M8x40	TORNILLO M8x40
	12	Y00043928	6	DADO FRENATO M8	SELF-LOCKING NUT M8	ECROU AUTOBLOQUANT M8	SELBSTSICHERNDE MUTTER M8	TUERCA AUTOBLOCANTE M8
	13	F000P01598	1	DISTANZIALE DESTRO	RIGHT SPACER	ENTRETOISE DROIT	ABSTANDHALTER RECHTS	DISTANCIADOR DERECHO
	14	F000P01599	1	DISTANZIALE SINISTRO	LEFT SPACER	ENTRETOISE GAUCHE	ABSTANDHALTER LINKS	DISTANCIADOR IZQUIERDO
	15	F000P01333	1	PERNO RUOTA	WHEEL AXLE	PIVOT DE ROUE	RADASCHE	EJE RUEDA
	16	800001688	1	PROTEZIONE CAMERA D'ARIA	AIR TUBE PROTECTION	VAIN DE PROTECTION	HULLE	VAINA DE PROTECCION
	17	Y00093072	1	DADO M20	NUT M20	ECROU M20	MUTTER M20	TUERCA M20
	18	F000P01335	1	CATENA 138 MAGLIE	CHAIN, 138 PITCHES	CHAÎNE 138 MAILLONS	KETTE 138 GLIEDER	CADENA 138 ESLABONES
	19	F000P02032	2	CUSCINETTO Ø47xØ20x14	BEARING Ø47xØ20x14	ROULEMENT Ø47xØ20x14	LAGER Ø47xØ20x14	COJINETE Ø47xØ20x14
	20	F000P02033	1	DISTANZIALE INTERNO	INTERNAL SPACER	ENTRETOISE INTÉRIEUR	INTERNER ABSTANDHALTER	DISTANCIADOR INTERNO
	21	F000P02027	1	ANELLO DI SUPPORTO	SUPPORT RING	BAGUE DE SUPPORT	HALTERUNG RING	ANILLO DE SOPORTE

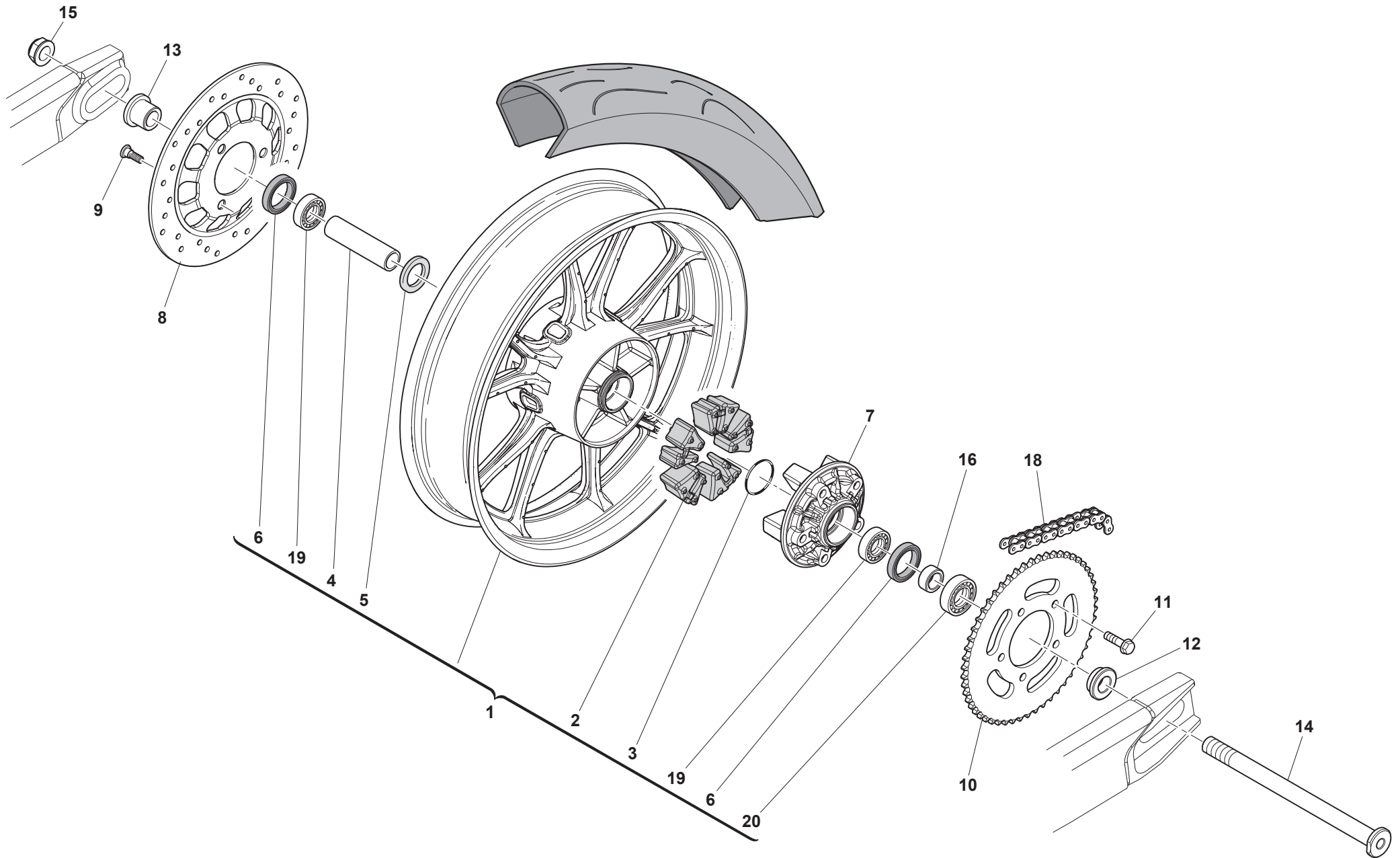



SM 125R/2017

**RUOTA POSTERIORE - REAR WHEEL
ROUE ARRIERE - HINTERRAD
RUEDA TRASERA**

TAVOLA
DRAWING
TABLE
BILD
TABLA

30A

Note Notes Marke Notas	Pos. No. Index Pos.	N. Cod. Code No. Nr. Code Code Nr N. Cod.	Q.tà Q.ty Q.te M.ge C.ad	DENOMINAZIONE	NAME	DESIGNATION	BESHREIBUNG	DENOMINACION
	1	F000A01606	1	RUOTA POSTERIORE SENZA PNEUMATICO	REAR WHEEL WITHOUT TYRE	ROUE ARRIÈRE SANS PNEU	HINTERRAD OHNE TYRE	RUEDA TRASERA SIN NEUMÁTICO
	2	F000P01607	5	PARASTRAPPI	ANTI-VIBRATION BUFFERS	AMORTISSEUR DE COUPLE	REIßSCHUTZ	ACOPAMIENTO ELÁSTICO
	3	F000P01608	1	ANELLO OR	O-RING	JOINT TORIQUE	O-RING	JUNTA TORICA
	4	F000P01609	1	DISTANZIALE INTERNO	INTERNAL SPACER	ENTRETOISE INTÉRIEUR	INTERNER ABSTANDHALTER	DISTANCIADOR INTERNO
	5	F000P01610	1	ANELLO DI SUPPORTO	SUPPORT RING	BAGUE DE SUPPORT	HALTERUNG RING	ANILLO DE SOPORTE
	6	F000P02035	2	PARAOILIO Ø42xØ30x7	OIL SEAL Ø42xØ30x7	JOINT PARE-HUILE Ø42xØ30x7	ÖLDICHTRING Ø42xØ30x7	RETÉN DE ACEITE Ø42xØ30x7
	7	F000P01612	1	ASSIEME SUPPORTO CORONA	SUPPORT SPROCKET ASSY	SUPPORT DE COURONNE COMPLET	ZAHNKRANZ HALTERUNG KOMPLETT	SOPORTE DE CORONA COMPLETO
	8	F000P01613	1	DISCO FRENO POSTERIORE	REAR BRAKE DISC	DISQUE DE FREIN	BREMSSCHEIBE	DISCO FRENO
	9	72012198	3	VITE	BOLT	VIS	SCHRAUBE	TORNILLO
	10	F000P01349	1	CORONA DENTATA Z=54	CHAIN SPROCKET T=54	COURONNE DENTÉE D=54	ZAHNKRANZ Z=54	CORONA DENTADA Z=54
	11	ZF0062797	5	VITE FISSAGGIO CORONA M10x30	CHAIN CONNECT CLIP BOLT M10x30	VIS DE FIXATION COURONNE M10x30	BEFESTIGUNG SCHRAUBE ZAHNKRANZ M10x30	TORNILLO FIJACIÓN CORONA M10x30
	12	F000P01614	1	DISTANZIALE SINISTRO	LEFT SPACER	ENTRETOISE GAUCHE	ABSTANDHALTER LINKS	DISTANCIADOR IZQUIERDO
	13	F000P01615	1	DISTANZIALE DESTRO	RIGHT SPACER	ENTRETOISE DROIT	ABSTANDHALTER RECHTS	DISTANCIADOR DERECHO
	14	F000P01333	1	PERNO RUOTA	WHEEL AXLE	PIVOT DE ROUE	RADASCHE	EJE RUEDA
	15	Y00093072	1	DADO M20x1,5	NUT M20x1,5	ECROU M20x1,5	MUTTER M20x1,5	TUERCA M20x1,5
	16	F000P01611	1	DISTANZIALE	SPACER	ENTRETOISE	ABSTANDHALTER	DISTANCIADOR
	17	F000P02032	1	CUSCINETTO Ø47xØ20x14	BEARING Ø47xØ20x14	ROULEMENT Ø47xØ20x14	LAGER Ø47xØ20x14	COJINETE Ø47xØ20x14
	18	FA00P01335	1	CATENA 136 MAGLIE	CHAIN, 136 PITCHES	CHAÎNE 136 MAILLONS	KETTE 136 GLIEDER	CADENA 136 ESLABONES
	19	F000P02031	2	CUSCINETTO Ø42xØ20x12	BEARING Ø42xØ20x12	ROULEMENT Ø42xØ20x12	LAGER Ø42xØ20x12	COJINETE Ø42xØ20x12
	20	F000P02065	1	PARAOILIO Ø42xØ30x7	OIL SEAL Ø42xØ30x7	JOINT PARE-HUILE Ø42xØ30x7	ÖLDICHTRING Ø42xØ30x7	RETÉN DE ACEITE Ø42xØ30x7

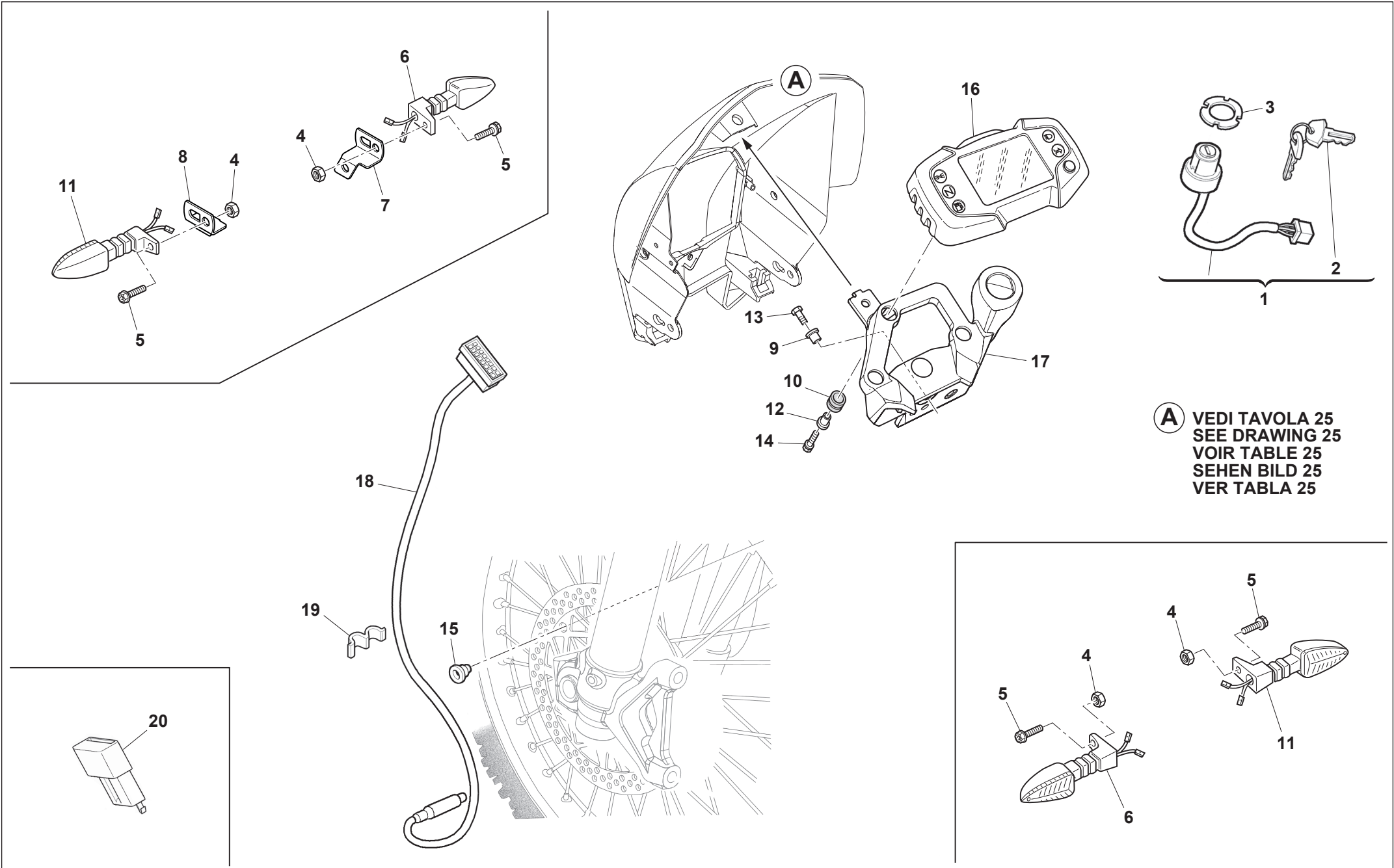

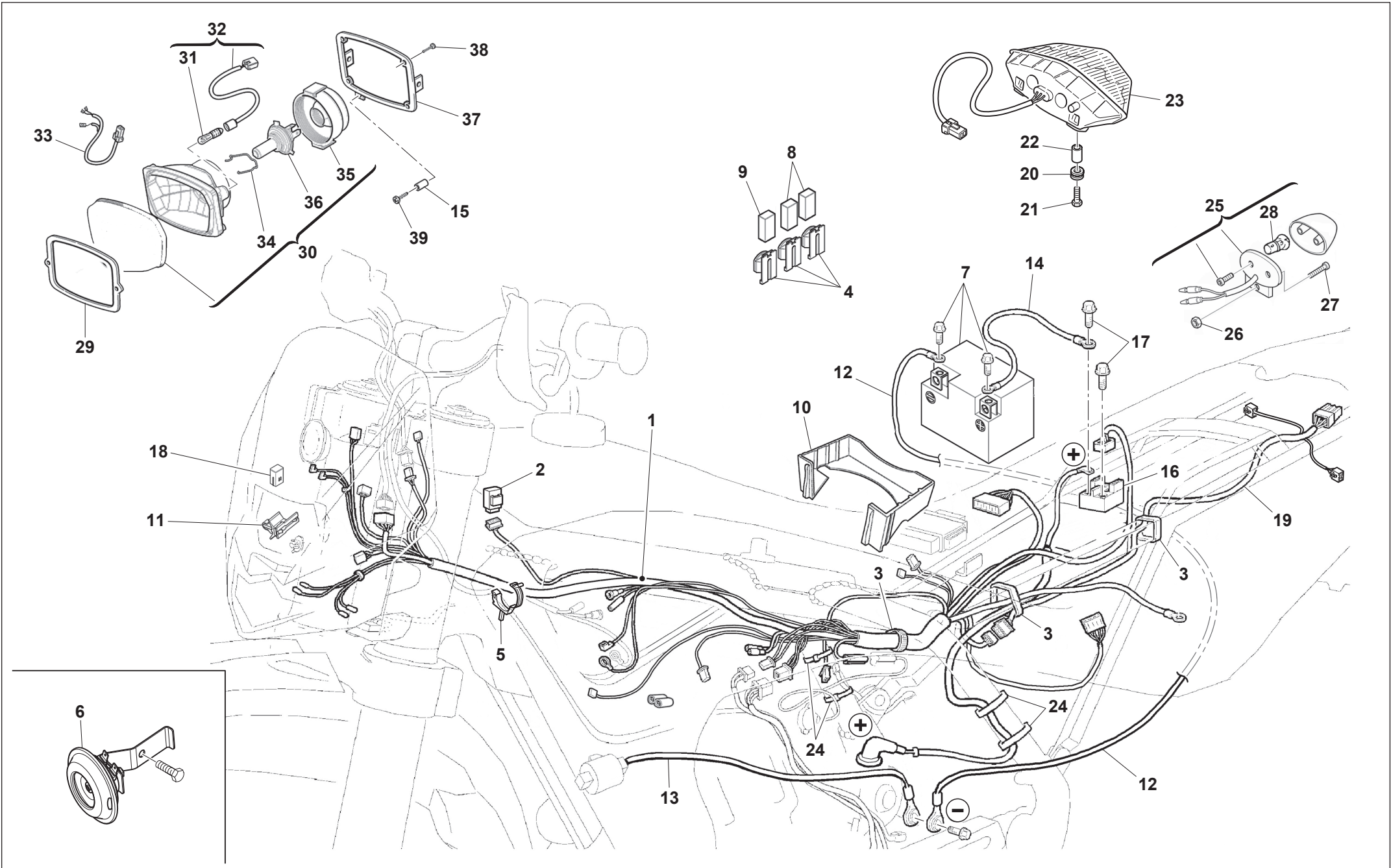



RS 125R/2017
SM 125R/2017

GRUPPO CAVI, PARTI ELETTRICHE - MAIN WIRING HARNESS, ELECTRICAL PARTS
CABLES PRINCIPAL, PARTIES ELECTRIQUES - KABEL, ELEKTRISCHE KOMPONENTE
GRUPO PRINCIPAL CABLES, PARTES ELECTRICAS

TAVOLA
DRAWING
TABLE
BILD
TABLA

32

Note Notes Marke Notas	Pos. No. N. Index Pos.	N. Cod. Code No. Nr. Code Code Nr N. Cod.	Q.tà Q.ty Q.te M.ge C.ad	DENOMINAZIONE	NAME	DESIGNATION	BESHREIBUNG	DENOMINACION
	1	E000P01523	1	IMPIANTO ELETTRICO	ELECTRIC SYSTEM	ÉLECTRIQUE INSTALLATION	ELEKTRIK PLANT	EQUIPO ELECTRICO
	2	8000A6749	3	RELÈ	RELAY	RELAIS	RELAIS	RELÉ
	3	800056444	11	FASCETTA L=188 mm	CLAMP L=188 mm	COLLIER L=188 mm	SHELLE L=188 mm	ABRAZADERA L=188 mm
	4	8000H0641	1	PORTAFUSIBILI	CASE FUSE	CORPS PORTE-FUSIBLES	SICHERUNGSKASTEN	CUERPO PORTAFUSIBLES
	5	8A0060283	2	MOLLETTA FERMACAVO	WIRE CLAMP	COLLIER, CORDON	KABELBINDER	GRAMPA CORDON
	6	E000A00026	1	AVVISATORE ACUSTICO	HORN	AVERTISSEUR SONORE	HUPE	AVISADOR ACÚSTICO
	7	E000P01571	1	BATTERIA 6AH	BATTERY 6AH	BATTERIE 6AH	BATTERIE 6AH	BATERÍA 6AH
	8	8F0095647	2	FUSIBILE 15A	FUSE 15A	FUSIBLE 15A	SICHERUNG 15A	FUSIBLE 15A
	9	8G0095647	1	FUSIBILE 20A	FUSE 20A	FUSIBLE 20A	SICHERUNG 20A	FUSIBLE 20A
	10	8000H0159	1	SUPPORTO BATTERIA	BATTERY SUPPORT	SUPPORT BATTERIE	BATTERIE HALTERUNG	SOPORTE BATERÍA
	11	8000H0644	2	CLIP	CLIP	COLLIER	SHELLE	ABRAZADERA
	12	8000B0254	1	CAVO BATTERIA-MASSA	BATTERY-EARTH CABLE	CÂBLE BATTERIE-MASSE	KABEL BATTERIE-MASSE	CABLE BATERÍA-MASA
	13	8000B0253	1	CAVO MASSA	EARTH CABLE	CÂBLE MASSE	MASSEKABEL	CABLE MASA
	14	8000B0826	1	CAVO BATTERIA-TELERUTTORE	BATTERY-SOLENOID STARTER CABLE	CÂBLE BATTERIE-TÉLÉRUPTEUR	KABEL BATTERIE-FERNRELAIS	CABLE BATERÍA-TELERRUPTOR
	15	8A00A1051	1	DISTANZIALE	SPACER	ENTRETOISE	ABSTANDHALTER	DISTANCIADOR
	16	8000H0809	1	TELERUTTORE AVVIAMENTO	SOLENOID STARTER	SOLENOÏDE DE DEMARRAGE	ANLASSER-FERNRELAIS	TELERRUPTOR ARRANQUE
	17	ZS0067545	2	VITE TEF M6x8	FLANGED EXAGON HEAD SCREW M6x8	BOULON DE BRIDE M6x8	FLANSCHENSCHRAUBE M6x8	TORNILLO DE REBORDE M6x8
	18	8000A6790	1	TAPPO CONNETTORE DIAGNOSI	DIAGNOSIS CONNECTOR CAP	BOUCHON CONNECTEUR DIAGNOSTIC	DECKEL DIAGNOSESTECKER	TAPON CONECTOR DIAGNOSTICO
	19	8000H1176	1	CAVO FANALE POSTERIORE	TAIL LIGHT CABLE	CÂBLE FEU ARRIÈRE	KABEL HECKSCHEINWERFER	CABLE PILOTO TRASERO
	20	800095128	2	GOMMINO	RUBBER RING	JOINT EN CAOUTCHOUC	GUMMISCHEIBE	GOMA
	21	Z00062727	2	VITE TEF M6x16	FLANGED EXAGON HEAD SCREW M6x16	BOULON DE BRIDE M6x16	FLANSCHENSCHRAUBE M6x16	TORNILLO DE REBORDE M6x16
	22	8000H1735	2	BOCCOLA FLANGIATA	FLANGED BUSHING	DOUILLE À BRIDE	FLANSCHBUCHSE	CASQUILLO CON BRIDA
	23	8000H1418	1	FANALE POSTERIORE	TAIL LIGHT	FEU ARRIÈRE	HECKSCHEINWERFER	PILOTO TRASERO
	24	8A0056444	5	FASCETTA L=188 mm	CLAMP L=188 mm	COLLIER L=188 mm	SHELLE L=188 mm	ABRAZADERA L=188 mm
	25	8000A0212	1	LUCE TARGA	LICENCE PLATE LIGHT	FEU DE PLAQUE	KENNZEICHENBELEUCHTUNG	LUZ MATRÍCULA
	26	61ND15192	1	DADO	NUT	ECROU	MUTTER	TUERCA
	27	60ND07330	1	VITE TCEI M5x16	SCREW TCEI M5x16	VIS TCEI M5x16	SCHRAUBE TCEI M5x16	TORNILLO TCEI M5x16
	28	800036230	1	LAMPADINA 12V/5W	WEDGE BASE BULB 12V/5W	AMPOULE 12V/5W	GLUEHLAMPE 12V/5W	LÁMPARA 12V/5W
	29	8000A1053	1	GUARNIZIONE	GASKET	JOINT	DICHTUNG	JUNTA
	30	8000H1736	1	FANALE ANTERIORE	FRONT HEADLAMP	FEU AVANT	FRONTSCHNWERFER	FARO DELANTERO
	31	800036230	1	LAMPADINA 12V/5W	WEDGE BASE BULB 12V/5W	AMPOULE 12V/5W	GLUEHLAMPE 12V/5W	LÁMPARA 12V/5W
	32	800095886	1	PORTALAMPADA POSIZIONE	SOCKET, PILOT LIGHT	PORTE AMPOULE, LAMPE-TEMOIN	FASSUNG, KONTROLLAMPE	PORTA-LAMPARA
	33	8000A6094	1	CAVO FANALE ANTERIORE	FRONT HEADLAMP CABLE	CÂBLE FEU AVANT	KABEL FRONTSCHNWERFER	CABLE FARO DELANTERO

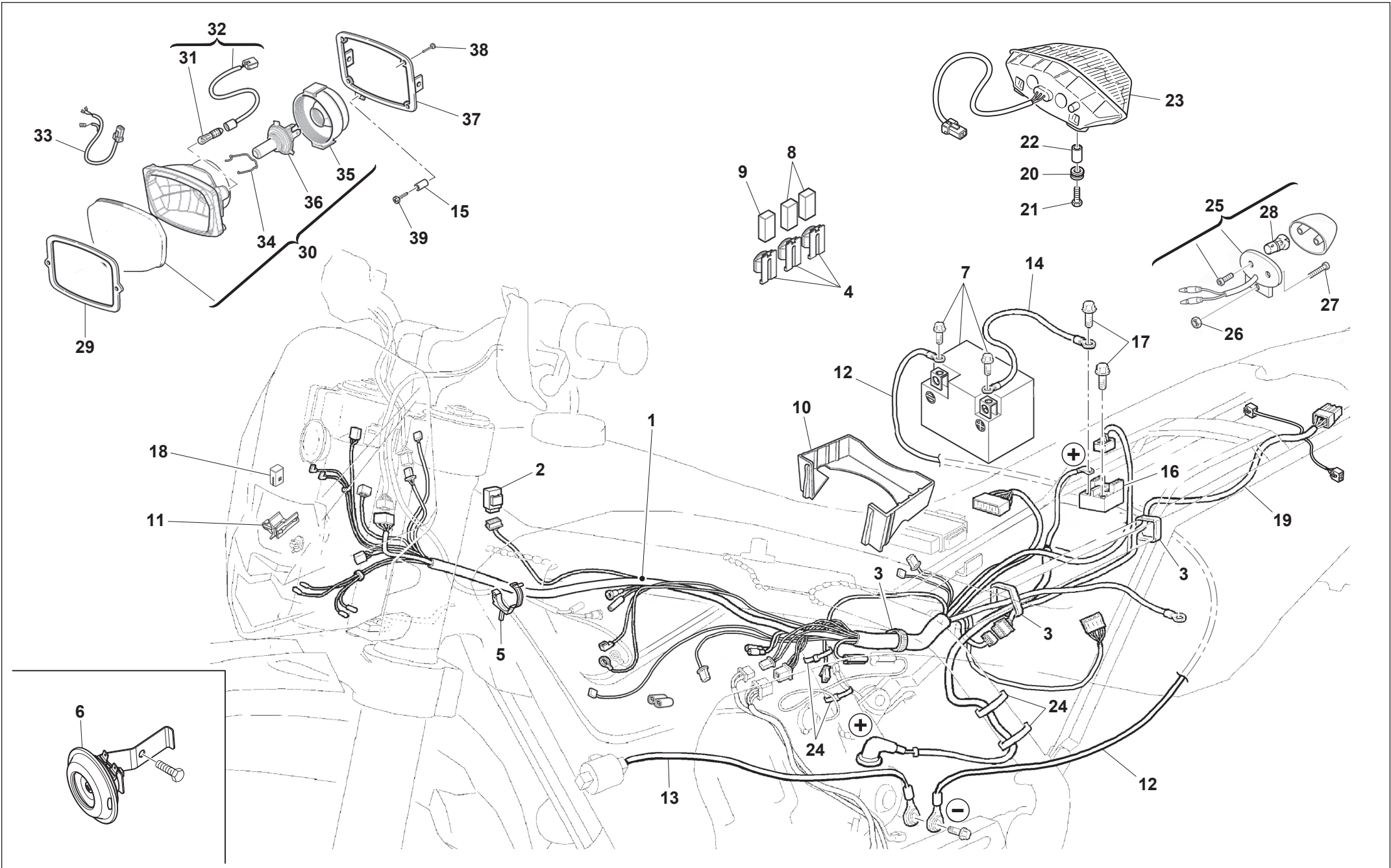

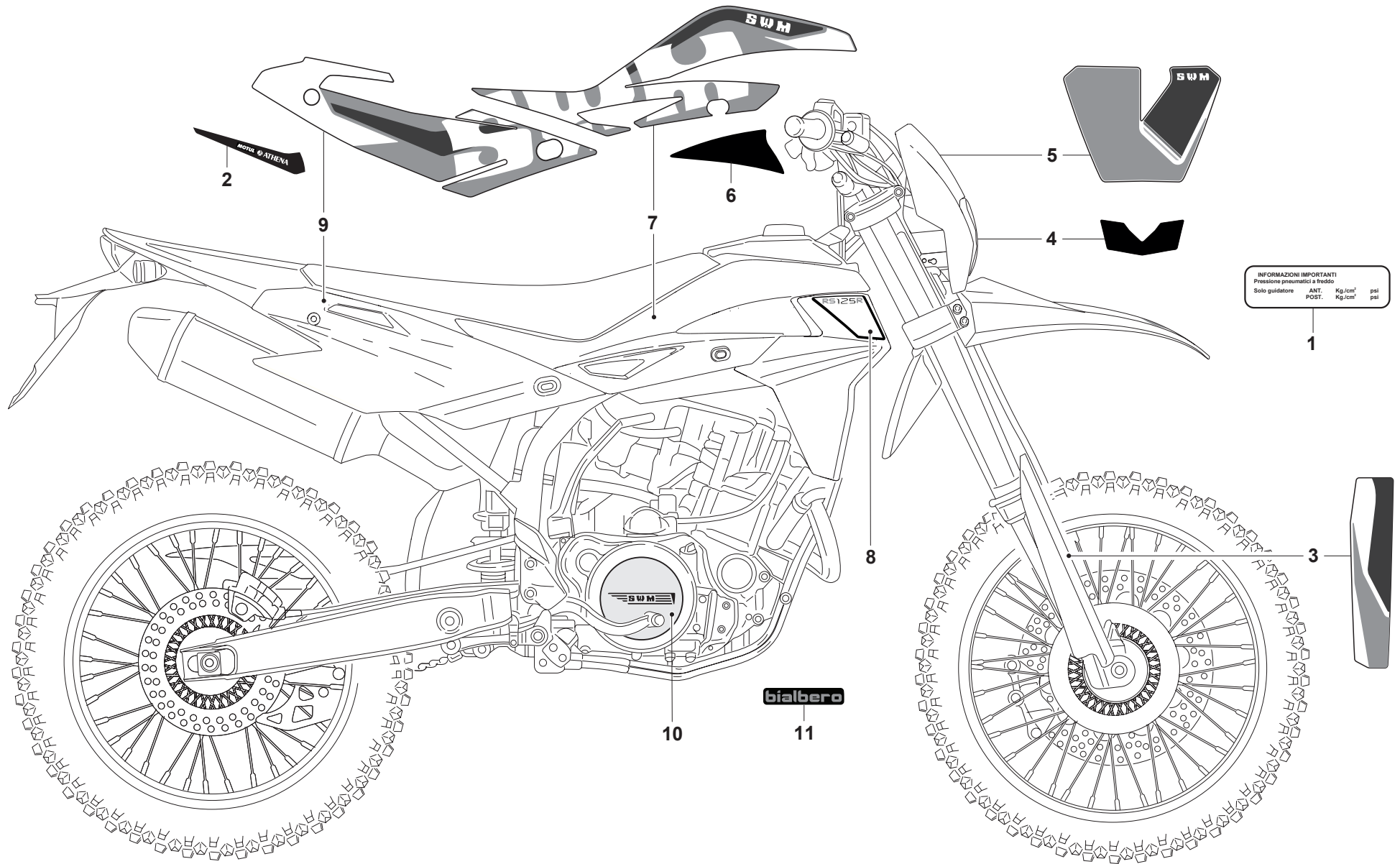

INFORMAZIONI IMPORTANTI
Pressione pneumatici a freddo

Solo guidatore	ANT.	Kg./cm ²	psi
	POST.	Kg./cm ²	psi

1

DECALCOMANIE - TRANSFER
DECALCOMANIE - ABZIEHBILD
CALCOMANIA

Note Notes Notes Marke Notas	Pos. No. N. Index Pos.	N. Cod. Code No. Nr. Code Code Nr N. Cod.	Q.tà Q.ty Q.te M.ge C.ad	DENOMINAZIONE	NAME	DESIGNATION	BESHREIBUNG	DENOMINACION
	1	800077871	1	ETICHETTA RACCOMANDAZIONI PNEUMATICI	LABEL, TIRE, INFORMATION	ETIQUETTE RECOMMANDATION PNEU	WARNSCHILD REIFEN EMPFEHLUNG	ETIQUETA RECOMENDACION NEUMATICOS
A	2	F000P01682	1	ADESIVO DESTRO	RIGHT STICKER	ADHÉSIF DROITE	AUFKLEBER RECHTS	ADHESIVO DERECHO
A	2	F000P01685	1	ADESIVO SINISTRO	LEFT STICKER	ADHÉSIF GAUCHE	AUFKLEBER LINKS	ADHESIVO IZQUERDO
B	2	FOA0P01682	1	ADESIVO DESTRO	RIGHT STICKER	ADHÉSIF DROITE	AUFKLEBER RECHTS	ADHESIVO DERECHO
B	2	FOA0P01685	1	ADESIVO SINISTRO	LEFT STICKER	ADHÉSIF GAUCHE	AUFKLEBER LINKS	ADHESIVO IZQUERDO
A	3	F000P01438	1	ADESIVO SINISTRO	LEFT STICKER	ADHÉSIF GAUCHE	AUFKLEBER LINKS	ADHESIVO IZQUERDO
A	3	F000P01439	1	ADESIVO DESTRO	RIGHT STICKER	ADHÉSIF DROITE	AUFKLEBER RECHTS	ADHESIVO DERECHO
B	3	FOA0P01438	1	ADESIVO SINISTRO	LEFT STICKER	ADHÉSIF GAUCHE	AUFKLEBER LINKS	ADHESIVO IZQUERDO
B	3	FOA0P01439	1	ADESIVO DESTRO	RIGHT STICKER	ADHÉSIF DROITE	AUFKLEBER RECHTS	ADHESIVO DERECHO
	4	F000P00811	1	STICKER CUPOLINO	COWLING STICKER	STICKER CAPOT	STICKER KOPFVERKLEIDUNG	ETIQUETA CUPULA
A	5	F000P01217	1	STICKER CUPOLINO	COWLING STICKER	STICKER CAPOT	STICKER KOPFVERKLEIDUNG	ETIQUETA CUPULA
B	5	FOA0P01217	1	STICKER CUPOLINO	COWLING STICKER	STICKER CAPOT	STICKER KOPFVERKLEIDUNG	ETIQUETA CUPULA
	6	F000P01440	1	ADESIVO SINISTRO	LEFT STICKER	ADHÉSIF GAUCHE	AUFKLEBER LINKS	ADHESIVO IZQUERDO
	6	F000P01441	1	ADESIVO DESTRO	RIGHT STICKER	ADHÉSIF DROITE	AUFKLEBER RECHTS	ADHESIVO DERECHO
A	7	F000P01218	1	DECAL CONVOGLIATORE DESTRO	DECAL SCOOP R.H.	DECAL DÉFLECTEUR DROIT	DECAL RECHTES LUFTLEITBLECH	DECAL DEFLECTOR AIRE DER.
A	7	F000P01219	1	DECAL CONVOGLIATORE SINISTRO	DECAL SCOOP L.H.	DECAL DÉFLECTEUR GAUCHE	DECAL LINKES LUFTLEITBLECH	DECAL DEFLECTOR AIRE IZQ.
B	7	FOA0P01218	1	DECAL CONVOGLIATORE DESTRO	DECAL SCOOP R.H.	DECAL DÉFLECTEUR DROIT	DECAL RECHTES LUFTLEITBLECH	DECAL DEFLECTOR AIRE DER.
B	7	FOA0P01219	1	DECAL CONVOGLIATORE SINISTRO	DECAL SCOOP L.H.	DECAL DÉFLECTEUR GAUCHE	DECAL LINKES LUFTLEITBLECH	DECAL DEFLECTOR AIRE IZQ.
A	8	F000P01688	1	DECAL PROTEZIONE RADIATORE SINISTRO	COVER, RADIATOR, DECAL L.H.	DECAL OUIE RADIATEUR GAUCHE	DECAL LINKES LEITBLECH	DECAL PROTECTOR RADIADOR IZQ.
A	8	F000P01689	1	DECAL PROTEZIONE RADIATORE DESTRO	COVER, RADIATOR, DECAL R.H.	DECAL OUIE RADIATEUR DROIT	DECAL RECHTES LEITBLECH	DECAL PROTECTOR RADIADOR DER.
B	8	F000P01686	1	DECAL PROTEZIONE RADIATORE DESTRO	COVER, RADIATOR, DECAL R.H.	DECAL OUIE RADIATEUR DROIT	DECAL RECHTES LEITBLECH	DECAL PROTECTOR RADIADOR DER.
B	8	FOA0P01688	1	DECAL PROTEZIONE RADIATORE SINISTRO	COVER, RADIATOR, DECAL L.H.	DECAL OUIE RADIATEUR GAUCHE	DECAL LINKES LEITBLECH	DECAL PROTECTOR RADIADOR IZQ.
A	9	F000P01224	1	EMBLEMA FIANCHETTO SINISTRO	EMBLEM, FRAME COVER L.H.	EMBLEME COUVERCLE CADRE GAUCHE	EMBLEM, SEITENABDECKUNG LINKS	EMBLEMA CUBIERTA LATERAL IZQ.
A	9	F000P01681	1	EMBLEMA FIANCHETTO DESTRO	EMBLEM, FRAME COVER R.H.	EMBLEME COUVERCLE CADRE DROIT	EMBLEM, SEITENABDECKUNG RECHTS	EMBLEMA CUBIERTA LATERAL DER.
B	9	F000P01693	1	EMBLEMA FIANCHETTO SINISTRO	EMBLEM, FRAME COVER L.H.	EMBLEME COUVERCLE CADRE GAUCHE	EMBLEM, SEITENABDECKUNG LINKS	EMBLEMA CUBIERTA LATERAL IZQ.
B	9	F000P01695	1	EMBLEMA FIANCHETTO DESTRO	EMBLEM, FRAME COVER R.H.	EMBLEME COUVERCLE CADRE DROIT	EMBLEM, SEITENABDECKUNG RECHTS	EMBLEMA CUBIERTA LATERAL DER.
	10	M000P01373	1	STICKER	STICKER	STICKER	STICKER	ETIQUETA
	11	M000P00257	1	STICKER	STICKER	STICKER	STICKER	ETIQUETA

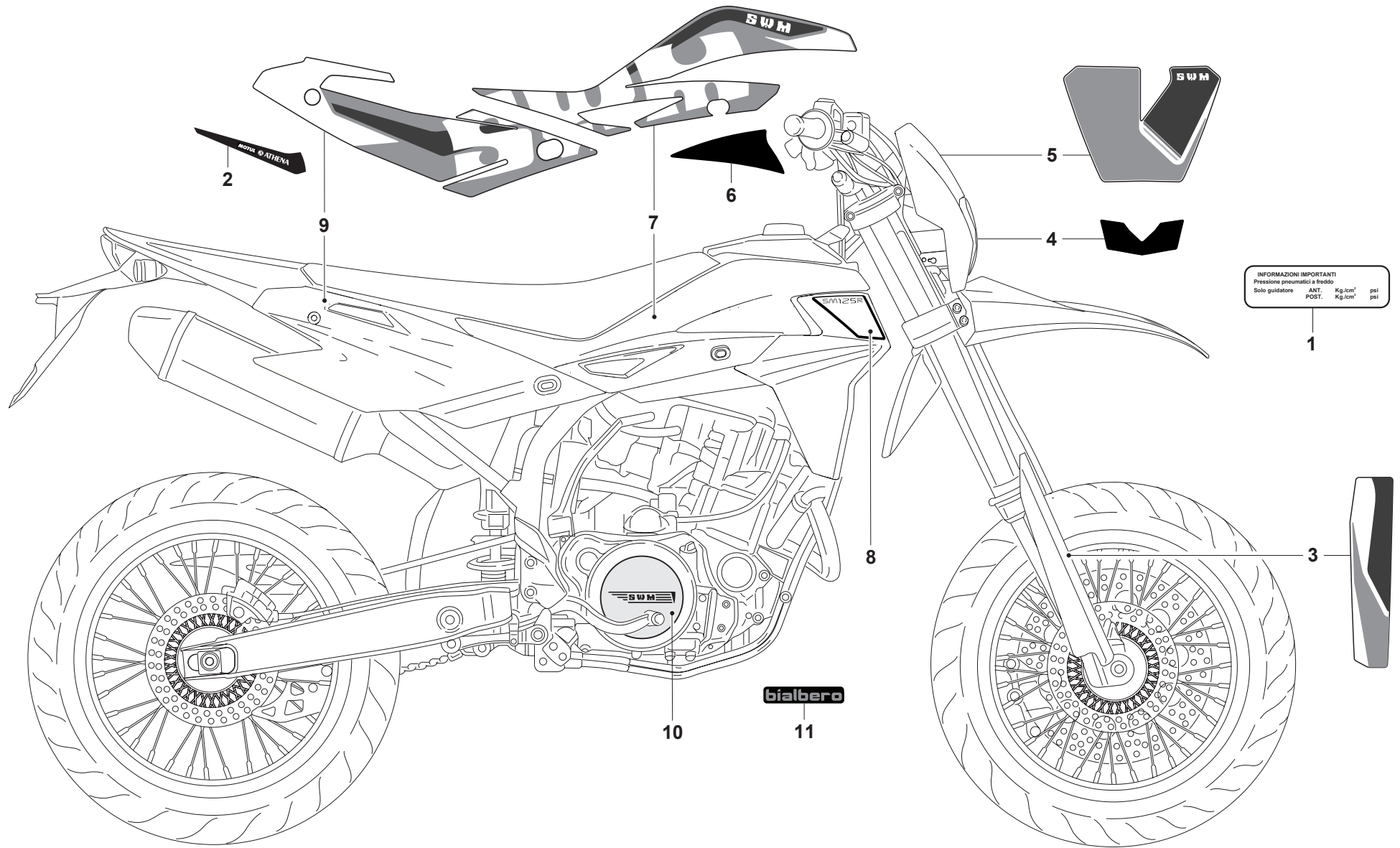

INFORMAZIONI IMPORTANTI
Pressione pneumatici a freddo
Solo guidatore ANT Kg/cm² psi
POST. Kg/cm² psi

DECALCOMANIE - TRANSFER
DECALCOMANIE - ABZIEHBILD
CALCOMANIA

Note Notes Notes Marke Notas	Pos. No. N. Index Pos.	N. Cod. Code No. Nr. Code Code Nr N. Cod.	Q.tà Q.ty Q.te M.ge C.ad	DENOMINAZIONE	NAME	DESIGNATION	BESHREIBUNG	DENOMINACION
	1	8A0077871	1	ETICHETTA RACCOMANDAZIONI PNEUMATICI	LABEL, TIRE, INFORMATION	ETIQUETTE RECOMMANDATION PNEU	WARNSCHILD REIFEN EMPFEHLUNG	ETIQUETA RECOMENDACION NEUMATICOS
A	2	F000P01682	1	ADESIVO DESTRO	RIGHT STICKER	ADHÉSIF DROITE	AUFKLEBER RECHTS	ADHESIVO DERECHO
A	2	F000P01685	1	ADESIVO SINISTRO	LEFT STICKER	ADHÉSIF GAUCHE	AUFKLEBER LINKS	ADHESIVO IZQUERDO
B	2	FOA0P01682	1	ADESIVO DESTRO	RIGHT STICKER	ADHÉSIF DROITE	AUFKLEBER RECHTS	ADHESIVO DERECHO
B	2	FOA0P01685	1	ADESIVO SINISTRO	LEFT STICKER	ADHÉSIF GAUCHE	AUFKLEBER LINKS	ADHESIVO IZQUERDO
A	3	F000P01438	1	ADESIVO SINISTRO	LEFT STICKER	ADHÉSIF GAUCHE	AUFKLEBER LINKS	ADHESIVO IZQUERDO
A	3	F000P01439	1	ADESIVO DESTRO	RIGHT STICKER	ADHÉSIF DROITE	AUFKLEBER RECHTS	ADHESIVO DERECHO
B	3	FOA0P01438	1	ADESIVO SINISTRO	LEFT STICKER	ADHÉSIF GAUCHE	AUFKLEBER LINKS	ADHESIVO IZQUERDO
B	3	FOA0P01439	1	ADESIVO DESTRO	RIGHT STICKER	ADHÉSIF DROITE	AUFKLEBER RECHTS	ADHESIVO DERECHO
	4	F000P00811	1	STICKER CUPOLINO	COWLING STICKER	STICKER CAPOT	STICKER KOPFVERKLEIDUNG	ETIQUETA CUPULA
A	5	F000P01217	1	STICKER CUPOLINO	COWLING STICKER	STICKER CAPOT	STICKER KOPFVERKLEIDUNG	ETIQUETA CUPULA
B	5	FOA0P01217	1	STICKER CUPOLINO	COWLING STICKER	STICKER CAPOT	STICKER KOPFVERKLEIDUNG	ETIQUETA CUPULA
	6	F000P01440	1	ADESIVO SINISTRO	LEFT STICKER	ADHÉSIF GAUCHE	AUFKLEBER LINKS	ADHESIVO IZQUERDO
	6	F000P01441	1	ADESIVO DESTRO	RIGHT STICKER	ADHÉSIF DROITE	AUFKLEBER RECHTS	ADHESIVO DERECHO
A	7	F000P01218	1	DECAL CONVOGLIATORE DESTRO	DECAL SCOOP R.H.	DECAL DÉFLECTEUR DROIT	DECAL RECHTES LUFTLEITBLECH	DECAL DEFLECTOR AIRE DER.
A	7	F000P01219	1	DECAL CONVOGLIATORE SINISTRO	DECAL SCOOP L.H.	DECAL DÉFLECTEUR GAUCHE	DECAL LINKES LUFTLEITBLECH	DECAL DEFLECTOR AIRE IZQ.
B	7	FOA0P01218	1	DECAL CONVOGLIATORE DESTRO	DECAL SCOOP R.H.	DECAL DÉFLECTEUR DROIT	DECAL RECHTES LUFTLEITBLECH	DECAL DEFLECTOR AIRE DER.
B	7	FOA0P01219	1	DECAL CONVOGLIATORE SINISTRO	DECAL SCOOP L.H.	DECAL DÉFLECTEUR GAUCHE	DECAL LINKES LUFTLEITBLECH	DECAL DEFLECTOR AIRE IZQ.
A	8	F000P01689	1	DECAL PROTEZIONE RADIATORE DESTRO	COVER, RADIATOR, DECAL R.H.	DECAL OUIE RADIATEUR DROIT	DECAL RECHTES LEITBLECH	DECAL PROTECTOR RADIADOR DER.
A	8	F000P01690	1	DECAL PROTEZIONE RADIATORE SINISTRO	COVER, RADIATOR, DECAL L.H.	DECAL OUIE RADIATEUR GAUCHE	DECAL LINKES LEITBLECH	DECAL PROTECTOR RADIADOR IZQ.
B	8	FOA0P01689	1	DECAL PROTEZIONE RADIATORE DESTRO	COVER, RADIATOR, DECAL R.H.	DECAL OUIE RADIATEUR DROIT	DECAL RECHTES LEITBLECH	DECAL PROTECTOR RADIADOR DER.
B	8	FOA0P01690	1	DECAL PROTEZIONE RADIATORE SINISTRO	COVER, RADIATOR, DECAL L.H.	DECAL OUIE RADIATEUR GAUCHE	DECAL LINKES LEITBLECH	DECAL PROTECTOR RADIADOR IZQ.
A	9	F000P01224	1	EMBLEMA FIANCHETTO SINISTRO	EMBLEM, FRAME COVER L.H.	EMBLEME COUVERCLE CADRE GAUCHE	EMBLEM, SEITENABDECKUNG LINKS	EMBLEMA CUBIERTA LATERAL IZQ.
A	9	F000P01681	1	EMBLEMA FIANCHETTO DESTRO	EMBLEM, FRAME COVER R.H.	EMBLEME COUVERCLE CADRE DROIT	EMBLEM, SEITENABDECKUNG RECHTS	EMBLEMA CUBIERTA LATERAL DER.
B	9	F000P01693	1	EMBLEMA FIANCHETTO SINISTRO	EMBLEM, FRAME COVER L.H.	EMBLEME COUVERCLE CADRE GAUCHE	EMBLEM, SEITENABDECKUNG LINKS	EMBLEMA CUBIERTA LATERAL IZQ.
B	9	F000P01695	1	EMBLEMA FIANCHETTO DESTRO	EMBLEM, FRAME COVER R.H.	EMBLEME COUVERCLE CADRE DROIT	EMBLEM, SEITENABDECKUNG RECHTS	EMBLEMA CUBIERTA LATERAL DER.
	10	M000P01373	1	STICKER	STICKER	STICKER	STICKER	ETIQUETA
	11	M000P00257	1	STICKER	STICKER	STICKER	STICKER	ETIQUETA